

ONEPOINTE SOLUTIONS

LABORATORY | INDUSTRIAL | COMMERCIAL



LABORATORY TABLE CATALOG

TABLE OF CONTENTS

Welcome	2	Countertops & Work Surfaces	
Quality Policy	3	• Traditional Lab Surfaces	33
Warranty	4	• Commercial Surfaces	34
Laboratory Tables		Finishes & Accessories	
• Anti-Vibration Table	6	• Powder Coat Colors	35
• Balance Table	7	• Table Accessories	36
• ESD Workbench	8	• Foot Options	38
• FLEX System	9	• Leg Options	39
• Hexagon Island	13	• Fume Hoods & Lab Fixtures	40
• Instrumentation Cart	15	Important Information	
• Mass Spec Bench	16	• Contact Us	41
• Microscope Table	18	• Nationwide Service	41
• Proteus Table	19		
• Stainless Steel Lab Table	20		
• Custom Lab Table	21		
Cabinet Additions & Features			
• Suspended Cabinets	23		
• Mobile Cabinets	27		
• Handles & Pulls	31		
• Concealed Hinges	32		

WELCOME

We are honored that you are considering our laboratory tables for your facility needs.

At OnePointe Solutions, we are continually improving the quality and versatility of our products to solve complex workspace issues.

We strive to exceed each customer's expectations via our products and our outstanding customer support.

Our goal is to bring about change through better designs, higher quality components, and customer service that is second to none.

Whether your project calls for a single table, a few workbenches, or a custom built workstation with all accessories from A to Z, we can make your vision a reality!

We are OnePointe Solutions!



QUALITY STATEMENT 2021

OnePointe Solutions' core business is the sale, design, layout, fabrication, and installation of custom industrial and laboratory furniture including casework, workbenches, fume hoods, and more. Our vision for growth and industry leadership is to provide aesthetically pleasing, functionally innovative, defect-free products in a timely manner.

We believe quality leadership in every functional area is necessary to remain a market leader, and as such continue to improve our Quality Management System (QMS) in line with the requirements of ISO 9001: 2015.

OnePointe Solutions executive team is committed to:

- Satisfying applicable requirements by ensuring that those of our customers along with any applicable statutory and regulatory requirements are determined, understood and consistently met.
- Continuous improvement of the QMS as the governing strategic tool to capture, then communicate a shared vision to stakeholders, iterate on, and execute from with respect to achieving customer requirements and growing customer satisfaction.

The OnePointe Solutions executive team shall:

- Maintain full accountability for the QMS.
- Consistently demonstrate quality leaderships in their respective areas of responsibility.
- Ensure the Quality Policy and respective quality objectives are established for the QMS and that they support the organizational context and strategy of the company.
- Establish quality objectives to be managed through performance data review, internal auditing, and the management review process to improve product quality, customer satisfaction and profitability.
- Utilize a process approach incorporating SIPOC and risk/opportunity based assessment.
Communicate and develop a shared understanding across the company as to the importance of quality management and QMS conformance.
- Ensure resources and personnel are available to execute to the intent and effectiveness of the QMS including providing time, training, and understanding of the strategy behind the QMS.
- Employ Kaizen as a tool for continuous improvement.
- Engage, direct, and support all personnel in their contribution towards the effective of the QMS and quality objectives.
- Partner with the supply chain on critical components to assure incorporated components meet performance and quality expectations.

This policy is communicated to all employees, organizations working in conjunction with OnePointe Solutions, and is provided to every quoted customer to share top management's vision and commitment to managing quality and continuous improvement in the design, manufacture and installation of beautiful industrial lab environments built to last.

Aaron Boto, CEO, OnePointe Solutions

WARRANTY

WHAT IS COVERED

OnePointe Solutions LLC (“OnePointe”) warrants the products sold are free of defects in materials or workmanship to the Purchaser under normal use and service for the warranty periods specified with the exceptions stated below.

WHO IS COVERED

This limited warranty only applies to an original Purchaser located in the United States, Canada, or Mexico.

HOW LONG COVERAGE LASTS

Coverage duration is dependent on the item(s) purchased, please reference the table below for details. Due to the custom nature of OnePointe’s products, there may be multiple items purchased, with different warranty durations. All warranties start from the date of shipment and run concurrently.

Item	Duration	Item	Duration
Countertops		Workbench Accessories	
Epoxy Resin*	1 Year	Lighting*	1 Year
Phenolic Resin*	1 Year**	Power Distribution*	1 Year
Laminate	1 Year	Foot Options*	1 Year
Maple Block*	1 Year	Shelving	5 Years
Stainless Steel	1 Year	Hydraulic Lifts*	1 Year
High Density Polyethelene (HDPE)*	1 Year	Uprights	Lifetime
Workbench Frames		Suspended Cabinets	
Fully Welded	Lifetime	Integrated Technology*	1 Year
Bolt Together	5 Years	Electrostatic Discharge (ESD) Devices*	1 Year
Casework / Fume Hoods		Other Furnishings	
Metal	5 Years	Chairs*	15 Years
Metal w/ Wood Fascia	1 Year	Service Fixtures*	1 Year
Fume Hoods*	1 Year	Lab Flooring*	5 Years
Blowers*	1 Year	Flammable / Chemical Safety Storage Cabinets*	1 Year
*Item is supplied by a third party; specific warranty will be assigned to the fullest extent allowed. **10 Year Delamination Warranty			

WHAT IS NOT COVERED

Defects resulting from normal wear and tear, color/grain variations, changes in surface finishes due to exposure to light, faulty installation, operation, disassembly, or remodeling, or from misuse, misapplication, neglect, abuse, accident, alteration, or the lack of proper maintenance, storage, cleaning, and care are not covered by OnePointe’s limited warranty. Products that are exposed to extreme environmental conditions or that have been subject to improper storage are not covered by OnePointe’s limited warranty. OnePointe does not provide warranty on components manufactured by others – only the original manufacturer’s warranty applies.

WARRANTY

WHAT ONEPOINTE SOLUTIONS WILL DO

OnePointe, as its sole obligation, will repair or replace (at its option) any product, part, or component covered by this warranty which fails perform to the product's specifications. If OnePointe acknowledges that any such defects found within the warranty period are the result of faulty material or workmanship, will repair or replace the product, part, or component with a comparable product, part, or component at its own expense. OnePointe may elect to provide on-site repair of defective product and in these cases, Buyer agrees to allow OnePointe factory technicians or authorized representative reasonable and timely access to jobsite during normal business hours. Repairs or replacement of product under warranty does not extend the original warranty period.

THERE ARE NO OTHER WARRANTIES, EXPRESSED OR IMPLIED, WHICH EXTEND BEYOND THE FACE HEREOF INCLUDING, WITHOUT LIMITATION, WARRANTIES OF MERCHANTABILITY OR FITNESS FOR A PARTICULAR USE.

The liability and remedy set forth above, in the event of a breach by OnePointe of its warranties set forth above or any of the covenants or agreements relating to the sale of the products to the Purchaser, shall be the sole and exclusive remedy to the Purchaser. In no event shall OnePointe's liability exceed the amount paid, excluding installation, by the Purchaser to OnePointe or any of its dealers or agents for the products to which the breach applies.

In no event shall OnePointe be liable to the Purchaser for any consequential or indirect damages including, but not limited to, loss of income, revenue, or profits in the event of a breach of any of the warranties or other covenants made by OnePointe with respect to the sale of OnePointe products to the Purchaser. The foregoing may not be modified except by a written amendment signed by OnePointe. The Purchaser, by accepting delivery of any product manufactured by OnePointe, hereby accepts the foregoing, and expressly waives any other remedy and damages, direct, indirect, and consequential.

HOW TO GET SERVICE

Contact OnePointe Solutions for any warranty questions or claims by phone **512.652.6292**, or email **warranty@onepointesolutions.com**. No product or parts thereof shall be returned to OnePointe or any of its dealers or agents without OnePointe's prior written consent. Product returned to OnePointe shall be shipped at buyers cost and risk of loss. Replacement product shall be returned at OnePointe's cost and risk of loss.

HOW STATE LAW APPLIES

This warranty gives you specific legal rights, and you may also have other rights which vary from state to state.



ANTI-VIBRATION TABLE

If your lab utilizes highly calibrated and sensitive equipment, vibrations from walls and heavy machinery can easily derail the special equipment by excessive imbalance/vibrations. Anti-vibration tables, from OnePointe Solutions, absorb the shock created by atmospheric/environmental vibrations, creating a stable surface on which to perform sensitive tasks.

Our anti-vibration tables are manufactured with cold-rolled powder-coated steel or 304 stainless steel to meet certain facility requirements and outfitted with anti-vibration levelers for the foot option. Built to be long-lasting, SEFA certified and, with various configurations to choose from, you can design and customize, with confidence, your ideal anti-vibration table for your laboratory.

Features

- Cleanroom Facility Compatible
- Heavy Duty Steel Construction
- Anti-Vibration Levelers
- Seamless Look & Feel
- Third-Party Independently Tested
- Fully-Welded Threaded Leg Inserts
- Multiple Size Options Available



Note: Model anti-vibration table displayed.
Not all accessories shown.
For full accessory list, go to pp. 36-37.

ANTI-VIBRATION TABLE CONFIGURATION OPTIONS

HEIGHTS	WIDTHS	DEPTHS
30"-36", ADA, ADJUSTABLE	36"-96"	24"-60"

FRAME MATERIAL	FRAME ASSEMBLY	FRAME TYPE	FOOT OPTIONS
POWDER-COATED STEEL STAINLESS STEEL	FULLY-WELDED BOLT-TOGETHER	C-FRAME H-FRAME	ANTI-VIBRATION LEVELERS

CUSTOM SIZES AVAILABLE UPON REQUEST

BALANCE TABLE

Marble Balance Table



Just like anti-vibration tables, balance tables absorb the shock created by atmospheric/environmental vibrations as well, providing a stable work surface to perform sensitive tasks and experiments on.

Reinforced with a lateral steel beam for additional support and rigidity, built to last and SEFA certified, our balance tables are capable of being a reliable addition to your lab for imperative and delicate tasks alike.

Note: Accessories are not compatible with balance tables.

MARBLE BALANCE TABLE SIZES

	HEIGHT	WIDTH	DEPTH	THICKNESS	WEIGHT	COLOR
TABLE D#101	31"	35"	24"	03"	450 lbs (net)	white on white
TABLE D#102	36"	35"	24"	03"	510 lbs (net)	white on white

Epoxy Resin Balance Table



EPOXY RESIN BALANCE TABLE COLORS

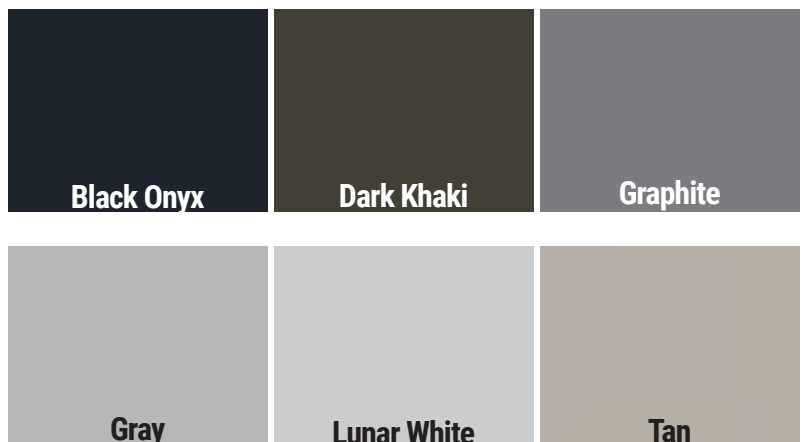

EPOXY RESIN BALANCE TABLE SIZE

HEIGHT	WIDTH	DEPTH	THICKNESS	WEIGHT
31"	35"	24"	2.5"	456 lbs (net)

CUSTOM SIZES UNAVAILABLE

ESD WORKBENCH

When working in an electrical sensitive environments, any type of lab table will not do. ESD workbenches and lab tables from OnePointe Solutions are designed to not only prevent high voltages from accumulating in these delicate spaces, but also customized to fit your exact specifications as well.

We cater to the EOS/ESD Association and can ensure the use of ANSI ESD S20.20 standards and that our furniture is UL listed if required. Made in America, built to be long-lasting, SEFA certified and with various configurations to choose from, so you can design and customize your ideal ESD table with confidence.

Features

- ESD Kit
- Cleanroom Facility Compatible
- Heavy Duty Steel Construction
- Seamless Look & Feel
- Third Party Independently Tested
- Fully Welded Threaded Leg Inserts
- Multiple Size Options Available



Note: Model ESD workbench displayed.
Not all accessories shown.
For full accessory list, go to pp. 36-37.

ESD WORK SURFACE COLORS

Black	Gray	White
--------------	-------------	--------------

ESD WORKBENCH CONFIGURATION OPTIONS

HEIGHTS	WIDTHS	DEPTHS
30"-36", ADA, ADJUSTABLE	36"-96"	24"-60"

FRAME MATERIAL	FRAME ASSEMBLY	FRAME TYPE	FOOT OPTIONS
POWDER-COATED STEEL STAINLESS STEEL	FULLY-WELDED BOLT-TOGETHER	C-FRAME H-FRAME	LEVELERS CASTERS ANCHOR FEET

CUSTOM SIZES AVAILABLE UPON REQUEST

FLEX SYSTEM

Our FLEX system is a great evolutionary solution for labs that need their furniture to grow as they do. Built with a height adjustable work surface, you will never have to fear being stuck in an uncomfortable position again.

You will be able to run services through the upright towers for easy surface area use. Unlike other tables, this system can have a work surface on both sides of a shared upright tower, allowing you to maximize your environment and save space.

Made in America, built to be long-lasting, and SEFA certified, you can design and customize, our FLEX system to fit your lab.

Features

- Single or Double Sided Assembly
- Perfect for Island Configuration
- Heavy Duty Construction
- Upright Assembly & Accepts All Upright Components
- Adjustable Shelving
- Height Adjustable Work Surface
- Adaptable Design
- Perfect for Mobile Storage

Note: Not all accessories shown.
For full accessory list, go to pp. 36-37.
*PLUMBING/MAX BUNDLE ONLY

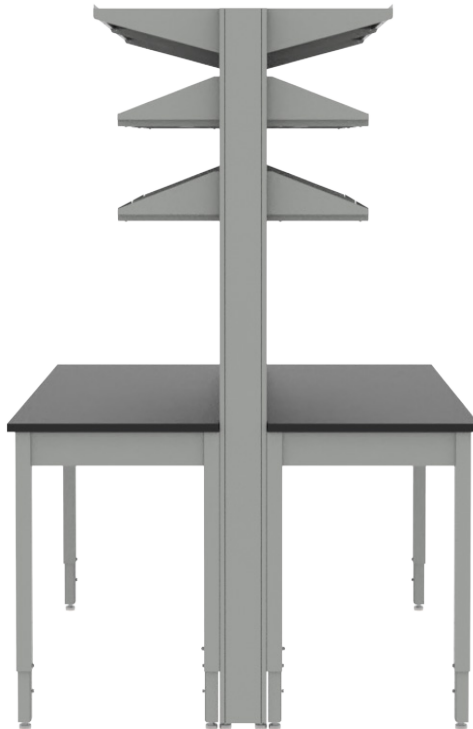

FLEX SYSTEM CONFIGURATION OPTIONS

HEIGHTS	WIDTHS	DEPTHS	FLEX BUNDLES	HOSE LENGTH*
84"	36", 42", 48", 54", 60", 66", 72", 84", 96"	30"-SINGLE SIDED (SS) 60"-DOUBLE SIDED (DS)	PLUMBING, RACEWAY, MAX	84", 96"

FLUID TYPE*	SHELF DEPTH	# OF SHELVES	WORK SURFACE	FRAME MATERIAL
HELIUM, AIR, COLD WATER VACUUM, GAS, ARGON, NITROGEN, OTHER	13", 16"	1,2,3,	PHENOLIC RESIN EPOXY RESIN	POWDER-COATED STEEL

CUSTOM SIZES UNAVAILABLE

FLEX SYSTEM BUNDLES

MAX FLEX BUNDLE



- (3) Rows of Shelves; Undermount Top Shelf
- Undersshelf Light Compatible
- (1) Air/Cold Water/Gas/Vacuum/Helium/Other/Argon/Nitrogen WSF Kit
 - Blade Handle Ball Valve
 - PVC Hose (Stainless Steel Hose for Gas and Nitrogen)
 - Quick Connects
- UL Verified Raceway
- Knockout Piece for Data Provisions on Upright



PVC Hose

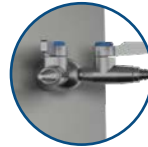

Valve

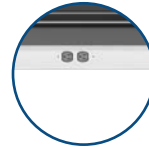

Raceway



Knockout Data Piece

PLUMBING FLEX BUNDLE



- (3) Rows of Shelves; Undermount Top Shelf
- Undersshelf Light Compatible
- (1) Air/Cold Water/Gas/Vacuum/Helium/Other/Argon/Nitrogen WSF Kit
 - Blade Handle Ball Valve
 - PVC Hose (Stainless Steel Hose for Gas and Nitrogen)
 - Quick Connects
- Knockout Piece for Data Provisions on Upright



PVC Hose

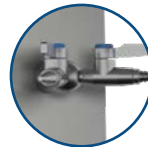

Valve



Knockout Data Piece

RACEWAY FLEX BUNDLE



- (3) Rows of Shelves; Undermount Top Shelf
- Undersshelf Light Compatible
- UL Verified Raceway
- Knockout Piece for Data Provisions on Upright



Raceway



Knockout Data Piece

FLEX SYSTEM CONFIGURATIONS

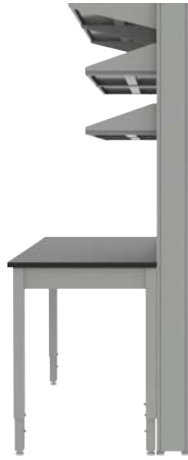

SINGLE-SIDED

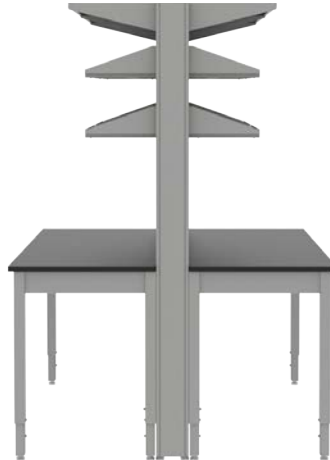

DOUBLE-SIDED



36" WIDTH



42" WIDTH



48" WIDTH



54" WIDTH



60" WIDTH



66" WIDTH



72" WIDTH



84" WIDTH

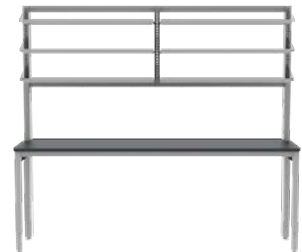

96" WIDTH

FLEX SYSTEM ACCESSORIES

CEILING PANEL

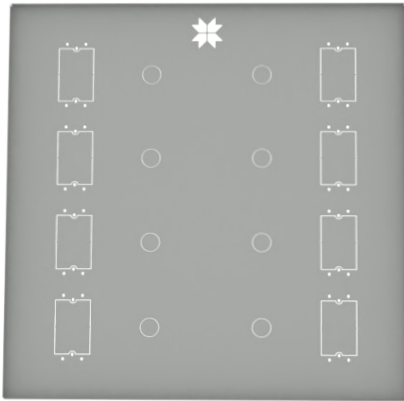

FXCP-WW-DD

Ceiling Panels comes with every FLEX System, regardless of configuration. Ceiling Panels can be shared by two adjacent FLEX Systems, accommodating a maximum of four plumbing services and four electrical connections per shared FLEX System. It is designed to be mounted on the ceiling grid and features pre-drilled holes for ease of installation.

CONFIGURATION OPTIONS

DOUBLE/SINGLE-SIDED	DEPTHS
DS/SS	13", 16"

OVERHEAD SERVICE CARRIER

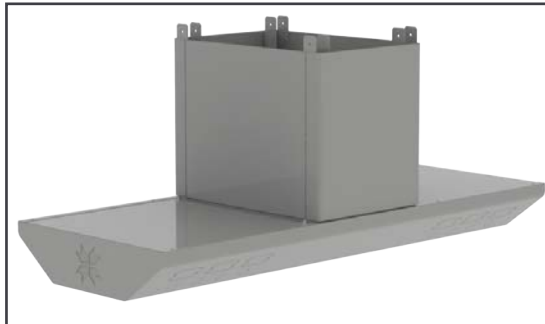

F-OHSC-WW

Overhead Service Carriers are designed to provide a convenient point of excess for Electrical and Plumbing connections at ceiling, with slight modification of service cover it can be used for other connections like ventilation, sanitary installations and lighting. Overhead Service Carriers free up space by elevating the power, data and service outlets overhead, creating maximum flexibility within your laboratory or office.

SHELVES



FXSAS-DS/SS-WWDD-UANG/ANG-PCS

CONFIGURATION CHART

FLEX WIDTH	36"	42"	48"	54"	60"	66"	72"	84"	96"
13" SHELF DEPTH	3613	4213	4813	2713D	3013D	3313D	3613D	4213D	4813D
16" SHELF DEPTH	3616	4216	4816	2716D	3016D	3316D	3616D	4216D	4816D

FLEX systems with widths of 54" or above, (2) shelves will be added to complete a row. Represented by "D" in the chart.

HEXAGON ISLAND

Hexagon islands are the perfect additions for K-12, university, and college labs. When you need to save space but want to make the most of it, hexagon islands are the solution.

They can be outfitted with sinks, gas, and water valves, or left as a bare surface to fulfill the needs of the room. The bases of the islands can be manufactured from cold-rolled powder-coated steel or 304 stainless steel to meet certain requirements in the facility.

As well as the bases can be a sink cabinet or base cabinet too. It just depends on what you need. Built to be long-lasting and SEFA certified, our hexagon islands are great for your academic classroom needs.

Features

- Promotes Collaborative Workspace
- Efficient Use of Floor Space
- Accommodates More Students Than Regular Table
- Hexagonal Shape Promotes Ease of Access to Sink
- Provides Work Surface While Being Seated or Standing
- Base or Sink Cabinet Foundation

Note: Not all accessories shown.
For full accessory list, go to pp. 36-37.



HEXAGON ISLAND CONFIGURATION OPTIONS

HEIGHTS*	WIDTHS	DEPTHS	WORK SURFACE
29", 32", 35", 41" *CABINET ONLY	BASE CABINET : 30", 36", 42", 48" SINK CABINET: 30", 36", 42", 48", 52", 58"	CABINET BASE: 18", 22	EPOXY RESIN
CABINET DOOR	CABINET DRAWER	LOCKING	PULLS
DOUBLE DOORS	0, 1, 2, 4	NO, YES	A=ALUMINUM PULL W=WIRE STAINLESS PULL

CUSTOM SIZES AVAILABLE UPON REQUEST

HEXAGON ISLAND CONFIGURATIONS

HEIGHTS

SITTING

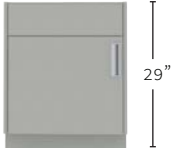

ADA



STANDARD



STANDING

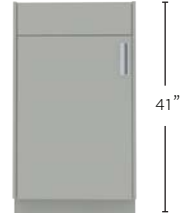

Overall hexagon island height (top + cabinet) will be affected by selected cabinet height above.

CABINET FOUNDATIONS



SINK-HHWDD-A/W



BASE-HHWDD-02-A/W



BASE-HHWDD-12-A/W



BASE-HHWDD-22-A/W



BASE-HHWDD-42-A/W

For all epoxy resin work surface color options, refer to page 33.

WORK SURFACE

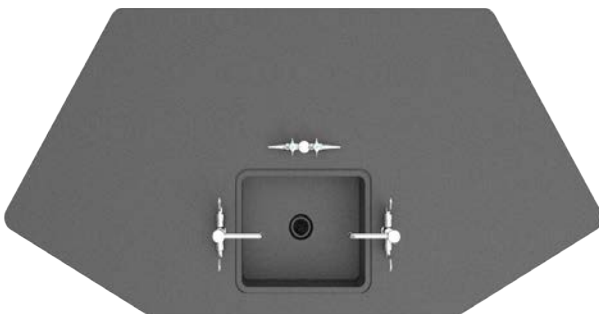

WITH SINK CUTOUT

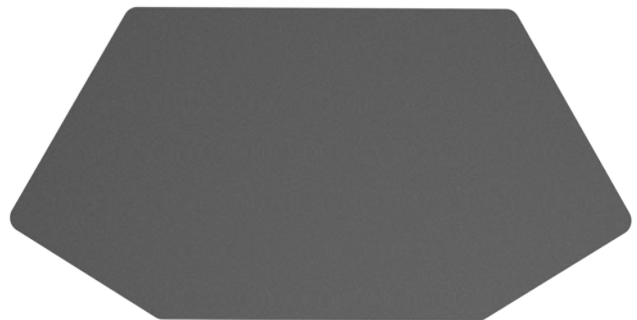

WITHOUT SINK CUTOUT

INSTRUMENTATION CART

Our instrumentation carts are custom-tailored solutions for complex lab instrumentation equipment. If you have an instrument shipping soon, we can work with you to develop a specialized bench or cabinet to house it.

Your instrumentation cart can be manufactured from cold-rolled powder-coated steel or 304 stainless steel to meet certain requirements in the facility.

Built to be long-lasting and SEFA certified, our instrumentation carts are a great addition to any laboratory.

Features

- Heavy Duty Steel Construction
- Seamless Look & Feel
- Third Party Independently Tested
- Bottom Shelf (Powder-Coated Steel, Stainless Steel or Matching Countertop Material)
- Fully Welded Threaded Leg Inserts
- Mobile for Easy Transportation of Equipment
- Multiple Size Options Available
- Top Matching Option Available



Note: Not all accessories shown.
For full accessory, go to pp. 36-37.

INSTRUMENTATION CART CONFIGURATION OPTIONS

HEIGHTS	WIDTHS	DEPTHS
30"-36", ADA	36"-96"	24"-60"

FRAME MATERIAL	FRAME ASSEMBLY	FOOT OPTIONS
POWDER-COATED STEEL STAINLESS STEEL	FULLY-WELDED	CASTERS

CUSTOM SIZES AVAILABLE UPON REQUEST

MASS SPEC BENCH

Our mass spec benches are ideal tailored solutions for complex lab processes and experiments including food and beverage testing, pesticide screening and other bioscience research.

Our line of mass spec benches are manufactured from cold-rolled powder-coated steel and come in (5) different models to give you flexibility and to meet certain requirements in the facility.

Built to be long-lasting and SEFA certified, our mass spec benches are a great addition to any lab space.

Features

- Standard 1" Lab Grade Phenolic Resin (Black) & Top Tray Surface
- Pull Out & Locking Pump Tray: 23.5" (W) x 21" D
- Sound Dampening Foam
- Temperature Sensors & Fail-Safe Alarm
- Rear Mounted Power Supply
- LED Light Start/Stop Switch
- (2) 205 CFM Fans
- (4) Grommet Holes
- Black GDR Leveling Casters
- Gas Cylinder Bracket (Select Models)
- Removable Back Door
- 5 Year Warranty



Note: Limited compatible accessories.
For compatible accessories, look for the (M) next to items on pp. 36-37.

MASS SPEC BENCH CONFIGURATION OPTIONS

HEIGHTS	WIDTHS	DEPTHS
30", 33", 36"	36", 48", 60", 72", 84", 96"	30", 34"

FRAME MATERIAL	FOOT OPTIONS
POWDER-COATED STEEL	BLACK GDR LEVELING CASTERS

CUSTOM SIZES UNAVAILABLE

MASS SPEC BENCH CONFIGURATIONS

COMPACT BENCH



CONFIGURATION OPTIONS

HEIGHTS	WIDTHS	DEPTHS
30", 33", 36"	36", 48"	30", 34"

COMPACT GC BENCH



CONFIGURATION OPTIONS

HEIGHTS	WIDTHS	DEPTHS
30", 33", 36"	36", 48"	30", 34"

WORK BENCH



CONFIGURATION OPTIONS

HEIGHTS	WIDTHS	DEPTHS
30", 33", 36"	60", 72", 84", 96"	30", 34"

GC BENCH



CONFIGURATION OPTIONS

HEIGHTS	WIDTHS	DEPTHS
30", 33", 36"	60", 72", 84", 96"	30", 34"

LC BENCH



CONFIGURATION OPTIONS

HEIGHTS	WIDTHS	DEPTHS
30", 33", 36"	60", 72", 84", 96"	30", 34"

MIRCROSCOPE TABLE

Microscope tables are made with specialized anti-vibration frames that are sturdy and can house different types of microscopes. Our tables can be outfitted with a standard work surface or specific cutout tabletops so that users can easily reach knobs and dial as well as rest arms and elbows during experiments.

And just like the rest of our lab tables, you can design and customize your microscope table to fit your facility needs exactly from a variety of sizes, accessories, and more. Your table frame can be made from either stainless steel or cold-rolled powder-coated steel frame to meet specific requirements in your lab.

Built to be long-lasting and SEFA certified, our microscope tables are the perfect addition to your laboratory.

Features

- Heavy Duty Steel Construction
- Seamless Look & Feel
- Third Party Independently Tested
- Fully Welded Threaded Leg Inserts
- Multiple Size Options Available
- Anti-Vibration Levelers
- Countertop Cut-Out Available Upon Request



Note: Model microscope table displayed.
Not all accessories shown.
For full accessory list, go to pp. 36-37.

MICROSCOPE TABLE CONFIGURATION OPTIONS

HEIGHTS	WIDTHS	DEPTHS
30"-36", ADA, ADJUSTABLE	36"-96"	24"-60"

FRAME MATERIAL	FRAME ASSEMBLY	FRAME TYPE	FOOT OPTIONS
POWDER-COATED STEEL STAINLESS STEEL	FULLY-WELDED BOLT-TOGETHER	C-FRAME H-FRAME	ANTI-VIBRATION LEVELERS

CUSTOM SIZES AVAILABLE UPON REQUEST

PROTEUS TABLE

Our Proteus table is designed to be the ultimate choice when you need adaptability, stability, and mobility. Built with our click-design through the entire upright, you are able to customize the height of every part of your table.

You can add and remove accessories based on your needs within seconds. Proteus tables come with leveling casters, allowing you to move your workstations around to help create an optimal workflow in your environment.

Made in America, built to be long-lasting, and SEFA certified, you can design and customize, with confidence, your ideal Proteus table for your lab.

Features

- Adaptable Design
- Heavy Duty Steel Construction
- Service Ready Uprights
- Optimized for Instrumentation
- Advanced Mobility and Leveling
- Fully Welded Base
- Height Adjustable Components
- Cantilevered Work Surface



Note: Not all accessories are shown.
For full accessories, go to pp. 36-37.

PROTEUS TABLE CONFIGURATION OPTIONS

HEIGHTS	WIDTHS	DEPTHS
80"	48", 60", 72"	30"
FRAME MATERIAL	UPRIGHTS	FOOT OPTIONS
POWDER-COATED STEEL	DUAL TRIPLE	LEVELING CASTERS

CUSTOM SIZES UNAVAILABLE

STAINLESS STEEL TABLE

Our stainless steel tables are perfect to have if you work in an environment where cleanliness and biosafety can't be compromised. Our tables are ground smooth to conceal weld spots, non-porous, durable, easy to clean, and eco-friendly.

The stainless steel we use is made in the USA, protected by our warranty, and available in standard or custom dimensions as well. Built to be long-lasting and SEFA certified, our stainless steel tables are the perfect addition to your lab facility.

Features

- Cleanroom Facility Compatible
- Heavy Duty Steel Construction
- Seamless Look & Feel
- Third Party Independently Tested
- Fully Welded Threaded Leg Inserts
- Multiple Size Options Available

Note: Model stainless steel table displayed.
Not all accessories not shown.
For full accessories, go to pp. 36-37.



STAINLESS STEEL TABLE CONFIGURATION OPTIONS

HEIGHTS	WIDTHS	DEPTHS
30"-36", ADA, ADJUSTABLE	36"-96"	24"-60"

FRAME MATERIAL	FRAME ASSEMBLY	FRAME TYPE	FOOT OPTIONS
STAINLESS STEEL	FULLY-WELDED BOLT-TOGETHER	C-FRAME H-FRAME	LEVELERS CATSERS ANCHOR FEET

CUSTOM SIZES AVAILABLE UPON REQUEST

CUSTOM LAB TABLE

Your Custom lab table is easily the most optimal selection to fit your needs. Using many of the elements that you have already seen and so much more, we can specifically design a table that 100% meets your needs.

Regardless of the size, load, or functional requirements, we can design, model, and construct a table that is completely unique to you and your environment. Don't settle for something that "kind of works," when you could have a table that is made just for you.

Made in America, built to be long-lasting, and SEFA certified, you can design and customize, with confidence, your ideal custom table for your lab.

Features

- Designed to Fit Your Space
- Fast Turnaround Times
- More Versatility
- In-House Design Team
- Better Return on Investment
- Manufacturer Direct
- Shop Drawing Approvals

Note: Not all accessories shown.
For full accessories, go to pp. 35-36.



ALL SIZES ARE CUSTOMIZED TO FIT YOUR SPECIFICATIONS

PAST CUSTOM DESIGNS



CUSTOM LAB TABLE

Need a bit of help coming up with your custom lab table? See below to check out some frames to aid in creating a foundation. **Note: Accessories are not shown. For accessories, go to pp. 35-36.**

BOLT TOGETHER FRAME



Your Bolt Together Frames are a great choice for those that desire to have sturdy table options, while needing flexibility to easily maneuver upon delivery. They are built with high quality 18ga tube steel legs, and are powder coated to the color of your choice. You will also add a 4" apron around the Bolt Together Frame, which is great for providing additional storage.

CONFIGURATION OPTIONS

HEIGHTS	WIDTHS	DEPTHS
30"-36", ADA	36"- 96"	24"-60"

FULLY-WELDED FRAME



Your Fully Welded Frames are the best choice when needing the strongest of the strong in your tables. They are built with 18ga tube steel, and are powder coated to the color of your choice. Outside welds are ground smooth to provide a seamless transition between joints. Fully Welded Frames will give you a sleek looking table that will impress in both ability and aesthetics.

CONFIGURATION OPTIONS

HEIGHTS	WIDTHS	DEPTHS
30"-36", ADA, ADJUSTABLE	36"- 96"	24"-60"

SIT/STAND FRAME



Your Sit/Stand Frames are the pinnacle of height adjustability for your environment. Once set, there is a simple one button process to go from sitting to standing and vice-versa. It even has the ability to accommodate multiple presets for separate users. The Sit/Stand Frames are second to none when needing an effortless posture change to increase productivity. Your most perfect solution for hours of data entry.

CONFIGURATION OPTIONS

HEIGHTS	WIDTHS	DEPTHS
ADJUSTABLE	36"- 96"	24"-60"

SUSPENDED CABINETS

Sometimes you need direct access to a cabinet without having to leave your work area. That's where our suspended cabinets come into play.

Our suspended cabinets are designed to be fastened beneath the work surface of any of our lab tables. Once installed they are a solution that is very robust and becomes part of the table.

Suspended cabinets can be manufactured in cold-rolled powder-coated steel or 304 stainless steel to accommodate different area requirements. Designed to be long-lasting and SEFA certified, our suspended cabinets are the perfect addition for your workspace needs.

Features

- 18 GA Sheet Metal Construction
- Soft-Closing Drawers and Doors
- 1x Adjustable Shelf (Doors)
- Concealed Hinges
- Heavy-Duty Construction



Understanding The Configuration Number

Using the model below, you will be able to better specify a cabinet configuration for your project.

SUS

Cabinet Type

- **HHWWDD**

Cabinet Dimensions

- **01L/RX**

Doors, Drawers & Locking

- **A/W**

Pull/ Handle Type

Drawers, Doors, Locking & Pull Details

I. Drawers

- First Number: # of Drawers (0 to 5)

II. Doors

- Second Number: # of Doors (0 to 2)
- L or R: Left or right hinged single door.
- For double doors, leave blank

III. Locking

- X : Locking
- No for locks, leave blank.

IV. Pulls

- A: Aluminum Pull
- W: Stainless Steel Wire Pull

Example: SUS-243620-22X-A

Suspended cabinet with 24" H x 36" W x 20" D, 2 Drawers, 2 Doors, Locking, Aluminum Pull

SUSPENDED CABINET CONFIGURATIONS

AVAILABLE HEIGHTS ARE LISTED ABOVE CONFIGURATIONS

1 DRAWER

SUS-HHWDD-10-A/W



2 DRAWERS

SUS-HHWDD-20-A/W



3 DRAWERS

SUS-HHWDD-30-A/W

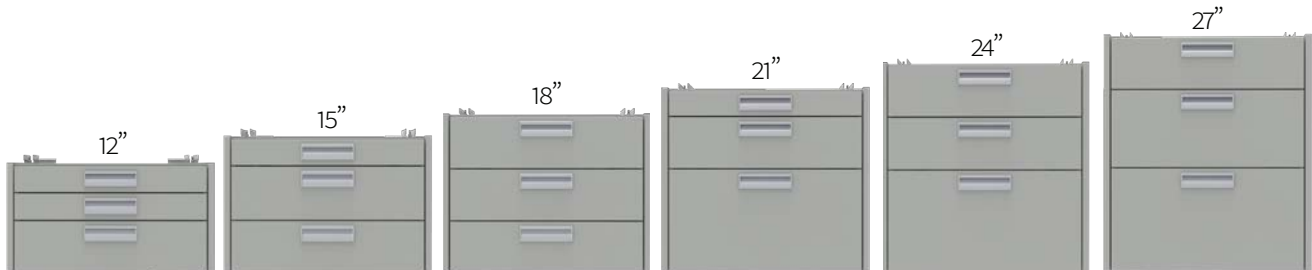

4 DRAWERS

SUS-HHWDD-40-A/W

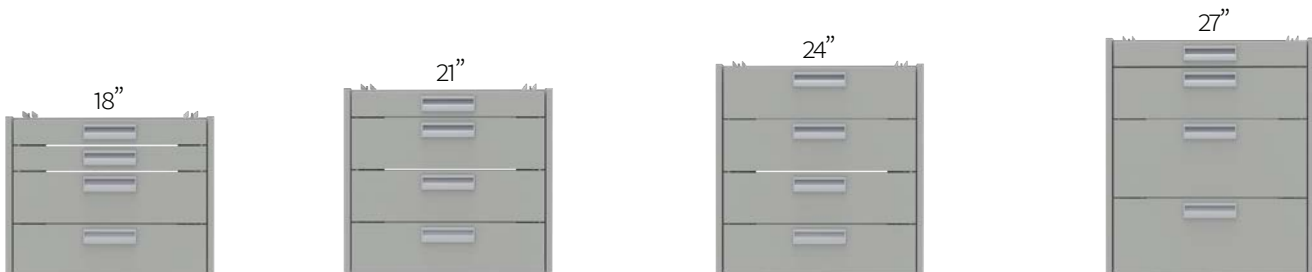

5 DRAWERS

SUS-HHWDD-50-A/W

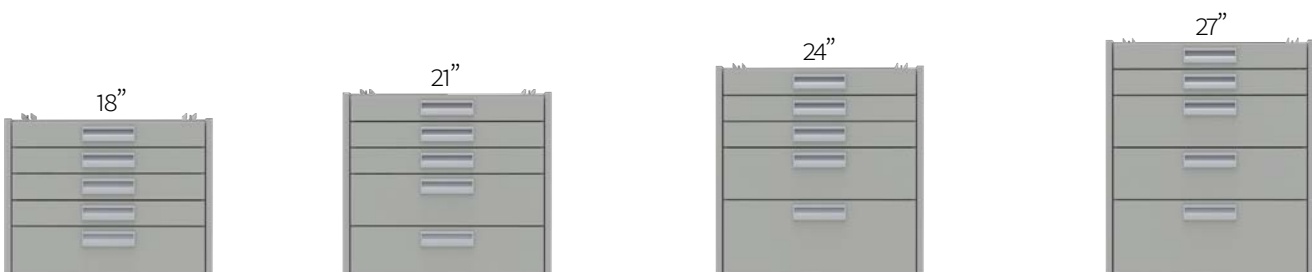

SUSPENDED CABINET CONFIGURATIONS

SUS-HHWDD-01L/R-A/W

SUS-HHWDD-02-A/W

1 DOOR

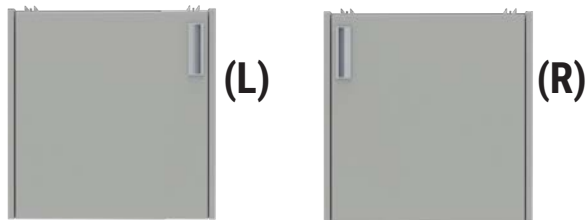

CABINETS WITH WIDTHS OF 24" OR LESS WILL HAVE (1) DOOR.
AVAILABLE HEIGHTS: 18", 21", 24", 27"

2 DOORS



CABINETS WITH WIDTHS OF 30" OR MORE WILL HAVE (2) DOORS.
AVAILABLE HEIGHTS: 18", 21", 24", 27"

DUAL COMBINATIONS



AVAILABLE HEIGHTS:
18", 21", 24", 27"

SUS-HHWDD-11L/R-A/W



AVAILABLE HEIGHTS:
ALL

SUS-HHWDD-00



AVAILABLE HEIGHTS:
18", 21", 24", 27"

SUS-HHWDD-12-A/W



AVAILABLE HEIGHTS:
21", 24", 27"

SUS-HHWDD-22-A/W

SUSPENDED CABINET CONFIGURATION OPTIONS

HEIGHTS	WIDTHS	DEPTHS	DRAWERS
03", 06", 09", 12", 15", 18", 21", 24", 27"	15", 18", 21", 24", 30", 36", 42", 48"	20", 22"	0 TO 5

DOORS	DOOR HINGE	LOCKING	PULLS
0 TO 2	L = LEFT R = RIGHT SKIP FOR DOUBLE DOOR	X=LOCKING SKIP FOR NO LOCKS	A = ALUMINUM PULL W = WIRE STAINLESS PULL

CUSTOM SIZES AVAILABLE UPON REQUEST

SUSPENDED CABINET COMPATIBILITY

SUSPENDED CABINET SKU CHART

SUSPENDED CABINET HEIGHT	SKU NUMBER
03"	SUS-03WWDD-R/LX-A/W
06"	SUS-06WWDD-R/LX-A/W
09"	SUS-09WWDD-R/LX-A/W
12"	SUS-12WWDD-R/LX-A/W
15"	SUS-15WWDD-R/LX-A/W
18"	SUS-18WWDD-R/LX-A/W
21"	SUS-21WWDD-R/LX-A/W
24"	SUS-24WWDD-R/LX-A/W
27"	SUS-27WWDD-R/LX-A/W

TABLE HEIGHTS (1.5" STEEL FRAME)	SUSPENDED CABINET HEIGHTS
30"-32"	03", 06", 09", 12", 15", 18", 21", 24"
32"-36"	03", 06", 09", 12", 15", 18", 21", 24", 27"
37" & UP	03", 06", 09", 12", 15", 18", 21", 24", 27"

TABLE HEIGHTS (2.0" STEEL FRAME)	SUSPENDED CABINET HEIGHTS
30"-32"	03", 06", 09", 12", 15", 18", 21", 24"
33"-36"	03", 06", 09", 12", 15", 18", 21", 24", 27"
37" & UP	03", 06", 09", 12", 15", 18", 21", 24", 27"

TABLE WIDTHS (1.5" OR 2.0" STEEL FRAME)	SUSPENDED CABINET WIDTHS
36"-41"	15", 18", 21", 24"
42"-47"	15", 18", 21", 24", 30"
48"-53"	15", 18", 21", 24", 30", 36"
54"-96"	15", 18", 21", 24", 30", 36", 42", 48"*

NOTE: Tables having widths of 60" or higher will accommodate 48" wide suspended cabinets.

MOBILE CABINETS

Whether your process requires it or if you just want to build the ultimate flexible lab, our mobile cabinets are a great solution. Furnishing your space with our mobile cabinets contributes to present-day adaptable and flexible space design techniques that are popular in any laboratory.

Mobile cabinets can be manufactured in cold-rolled powder-coated steel or 304 stainless steel to accommodate different area requirements. Designed to be long-lasting and SEFA certified, our suspended cabinets are the perfect addition to your workspace needs.

Features

- 18 GA Sheet Metal Construction
- Soft-Closing Drawers and Doors
- 1x Adjustable Shelf
- Plate Casters
- Standard 1" Metal Top or Lab Worksurface
- Anti-Tip Design
- Concealed Hinges
- Heavy-Duty Construction



Understanding The Configuration Number

Using the model below, you will be able to better specify a cabinet configuration for your project.

MOB

Cabinet Type

- **HHWWDD**

Cabinet Dimensions

- **01L/RX**

Doors, Drawers & Locking

- **A/W**

Pull/ Handle Type

Drawers, Doors, Locking & Pull Details

<p>I. Drawers</p> <ul style="list-style-type: none"> • First Number: # of Drawers (0 to 5) 	<p>II. Doors</p> <ul style="list-style-type: none"> • Second Number: # of Doors (0 to 2) • L or R: Left or right hinged single door. • For double doors, leave blank. 	<p>III. Locking</p> <ul style="list-style-type: none"> • X : Locking • No for locks, leave blank. 	<p>IV. Pulls</p> <ul style="list-style-type: none"> • A: Aluminum Pull • W: Stainless Steel Wire Pull
-----------------------------------------------------------------------------------------------------------	--------------------------------------------------------------------------------------------------------------------------------------------------------------------------------------------------------	---------------------------------------------------------------------------------------------------------------------------	-------------------------------------------------------------------------------------------------------------------------------

Example: MOB-352122-40-A

Mobile cabinet with 35" H x 21" W x 22" D, 4 Drawers, No Locking, Aluminum Pull

MOBILE CABINET CONFIGURATIONS

AVAILABLE HEIGHTS ARE LISTED ABOVE CONFIGURATIONS.
NOTE: HEIGHTS DO NOT ACCOUNT FOR THE 1" TOP THAT NEEDS TO BE SELECTED ON MOBILE CABINETS.

2 DRAWERS

MOB-HHWDD-10-A/W



3 DRAWERS

MOB-HHWDD-30-A/W



4 DRAWERS

MOB-HHWDD-40-A/W



5 DRAWERS

MOB-HHWDD-50-A/W



MOBILE CABINET CONFIGURATIONS

MOB-HHWDD-01L/R-A/W

1 DOOR

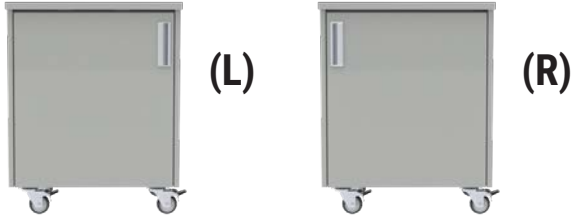

CABINETS WITH WIDTHS OF 24" OR LESS WILL HAVE (1) DOOR.

MOB-HHWDD-02-A/W

2 DOORS



CABINETS WITH WIDTHS OF 30" OR MORE WILL HAVE (2) DOORS.

DUAL COMBINATIONS



MOB-HHWDD-11L/R-A/W

AVAILABLE HEIGHTS:
ALL



MOB-HHWDD-12-A/W

AVAILABLE HEIGHTS:
26", 29", 32", 35"



MOB-HHWDD-22-A/W

AVAILABLE HEIGHTS:
26", 29", 32", 35"

MOBILE CABINET CONFIGURATION OPTIONS

HEIGHTS	WIDTHS	DEPTHS	DRAWERS
23", 26", 29", 32', 35"	15", 18", 21", 24", 30", 36", 42", 48"	20", 22"	0 TO 5
DOORS	DOOR HINGE	LOCKING	PULLS
0 TO 2	L = LEFT R = RIGHT SKIP FOR DOUBLE DOOR	X=LOCKING SKIP FOR NO LOCKS	A = ALUMINUM PULL W = WIRE STAINLESS PULL

CUSTOM SIZES AVAILABLE UPON REQUEST

MOBILE CABINET COMPATABILITY

MOBILE CABINET SKU CHART

MOBILE CABINET HEIGHT	SKU NUMBER
23"	MOB-23WWDD-R/LX-A/W
26"	MOB-26WWDD-R/LX-A/W
29"	MOB-29WWDD-R/LX-A/W
32"	MOB-32WWDD-R/LX-A/W
35"	MOB-35WWDD-R/LX-A/W

TABLE HEIGHTS	MOBILE CABINET HEIGHTS
37" or TALLER	23", 26", 29", 32"
36"	23", 26", 29", 32"
35"	23", 26", 29", 32"
34"	23", 26", 29"
33"	23", 26", 29"
32"	23", 26", 29"
31"	23", 26"
30"	23", 26"

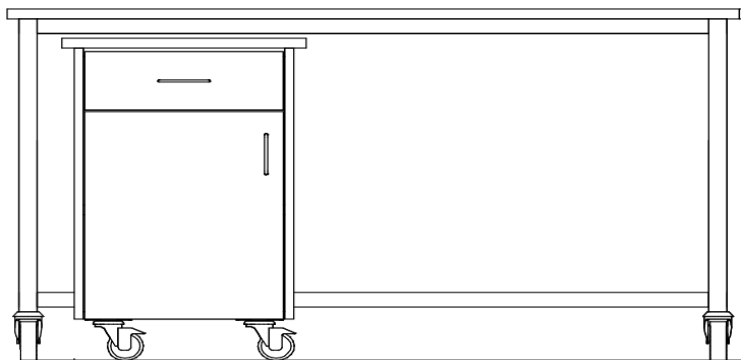
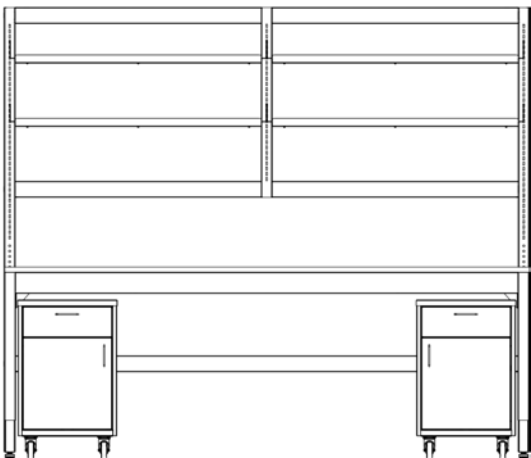

HANDLES & PULLS

Stainless Steel Wire Pulls



Aluminum Recessed Handles

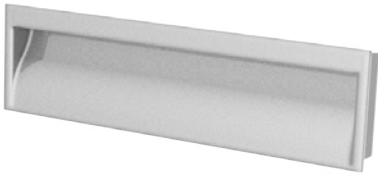

Powder Coat Options Available



Black Recessed Handles

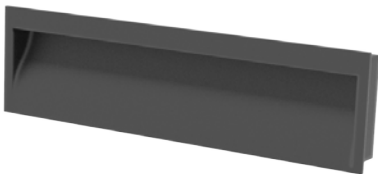

Custom Pull Options Available



CONCEALED HINGES



APPEARANCE



HINGE MOTION



INNOVATIVE TECHNOLOGY



SILENT & EFFORTLESS MOTION

Features

SEFA Certified | Quieter Lab | Tested to 100,000 Cycles | Three Dimensional Adjustments | No Institutional Exposed Hinges

LABORATORY SURFACES

Epoxy Resin



Epoxy resin is a quality material that is resistant to most chemicals, moisture, impact, and heat; it's the ideal solution for environments that are very corrosive or have a high level of moisture.

Phenolic Resin



Phenolic resin countertops and tabletops meet the requirements of most laboratories while including additional benefits such as chemical, wear, and water resistance.

Stainless Steel



Stainless steel is the ultimate solution for adding resistance to your workspace. As a nonporous surface, no liquid or substance can penetrate into the material; bacteria, mold, and other common germs don't stand a chance.

ESD Laminate

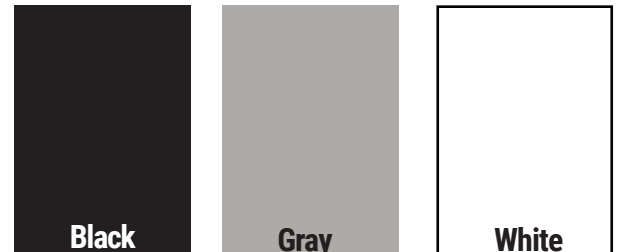

ESD Laminate or electro-static dissipative laminate is specifically designed to prevent the discharge of built-up static electricity that can damage sensitive equipment.

Solicor-CR

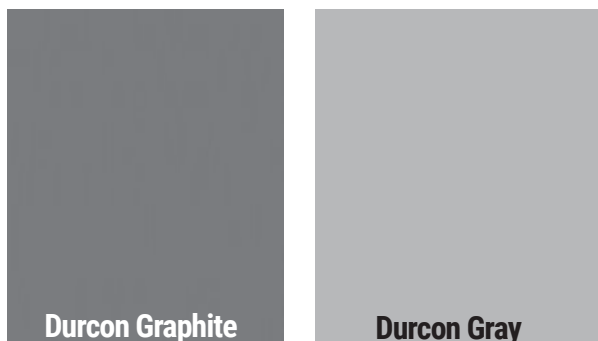

Solicor-CR is a lab-grade surface material well suited for environments, where chemical resistance, durability and aesthetics are top priorities.

HDPE

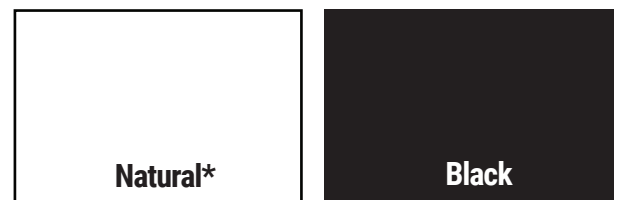

High-Density Polyethylene (HDPE) tops are lightweight and provide a non-absorbent and stain-free surface that is best used for food preparation.

*FDA approved & NSF Standard 51 certified

COMMERCIAL SURFACES

Maple Block



In the material handling business, there's no better than maple block. Maple works hard in factories in kitchens, and on shipping and receiving docks around the world.

Granite



Granite countertops are an elegant, timeless, and extremely durable surface option. They bring any commercial or industrial space to life with its many colors and smooth finish.

For our granite countertop colors, please contact us.

Quartz



Quartz countertops are favored by designers in various commercial industries since quartz can easily withstand extended use, regular cleaning, and exposure to moderate heat, moisture, and most household/commercial cleaners.

For our quartz countertop colors, please contact us.

Plastic Laminate



Made to align perfectly with your target aesthetic, layout, and budget. From breakrooms and reception areas to conference rooms, classrooms and even laboratories, plastic laminate countertops complement virtually any environment it is in.

For our plastic laminate countertop colors, please contact us.

Wilsonart® Solid Surface



At OnePointe Solutions, we carry a plethora of Wilsonart® Solid Surface options. Wilsonart® Solid Surface countertops are great for use in many settings: office, retail, industrial, healthcare, education and in certain laboratory settings. It is nonporous, seamless, elegant and can mimic the look of granite marble and even stone. Above are some of our quick ship options. For more solid surface options, please contact us.

POWDER COAT COLORS

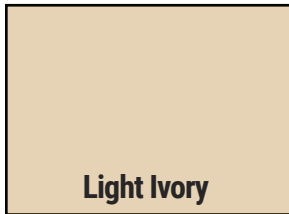
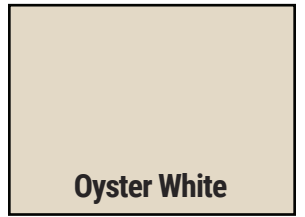
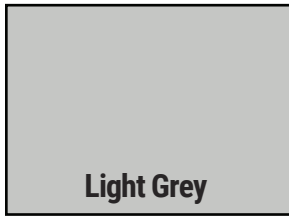

(Gloss/Matte/Texture)

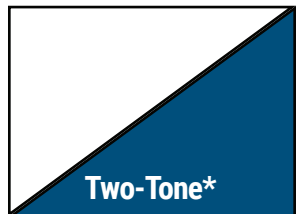
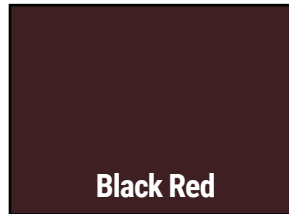
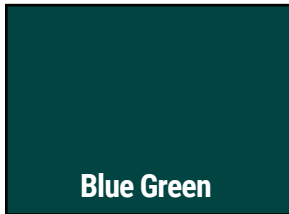
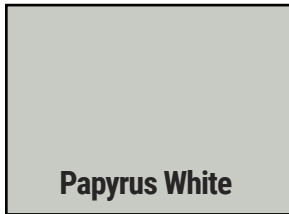
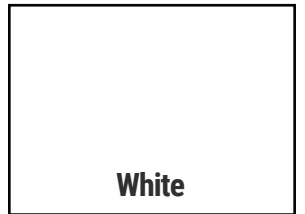

*Available Upon Request

NON POWDER COAT OPTION



NEED A CUSTOM COLOR?

Want a color you do not see? No worries we can help you get virtually any color for your casework. What are you looking for? A certain red? Deep blue? Special white? Let us know and we will do our best to get you virtually any color in the color wheel and even those that are not too. Our fabrications can be faced with a wide selection of hues and finishes, from bold to subdued. ***Note: Some colors may require a minimum order. ***

TABLE ACCESSORIES



FULL LOWER SHELF



HALF LOWER SHELF



MODESTY PANEL

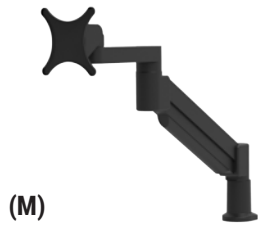

(M)

MONITOR ARM



(M)

KEYBOARD HOLDER



(M)

CPU HOLDER

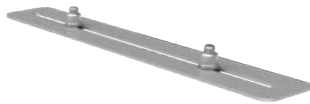

CONNECTOR PLATE

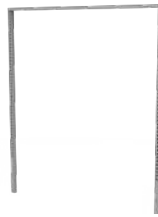

DUAL UPRIGHTS

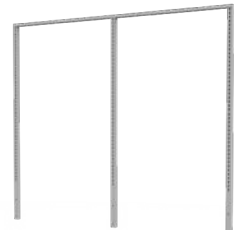

TRIPLE UPRIGHTS



FULL UPPER SHELF

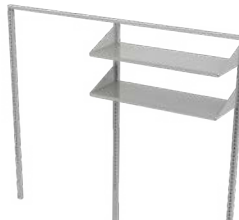

HALF UPPER SHELF



STEEL CABINET



GLASS CABINET

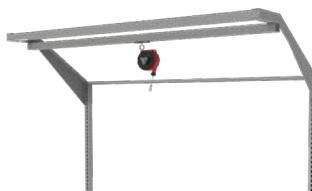

TOOL BALANCER, RAIL & TROLLEY

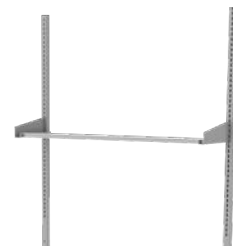

ROLL HOLDER

TABLE ACCESSORIES



UPPER SHELF

With Steel Surface



UPPER SHELF - UNDERMOUNT

With Steel Surface



LIGHT KITS - OVERHEAD



UPPER SHELF

Non-Metal Surface



UPPER SHELF - UNDERMOUNT

Non-Metal Surface



LIGHT KITS - UNDERMOUNT



VERTICAL SHELF DIVIDERS



GROMMET HOLES

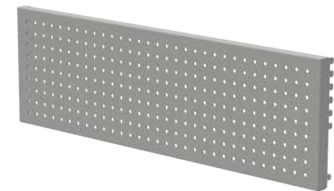

PEGBOARD/DRYING RACK

Metal (Half and Full Width)



BIN BOX RAILS



(M)

POWER STRIP

SPECIALTY ITEMS

- Edge Rails
- Foot Rests & Ergonomic Support Systems
- Power, Data & Plumbing Raceways
- Surge Protection
- Wire Management



FOOT OPTIONS



NYLON LEVELER

FOOT-LVLR-CHROME
Load Rating (Per Set of 4): 1,200 lbs



ANTI-VIBRATION LEVELER

FOOT-LVLR-AV3.75
Load Rating (Per Set of 4): 3,000 lbs



HEAVY DUTY LEVELER

FOOT-LVLR-HD
Load Rating (Per Set of 4): 10,000 lbs



TOTAL LOCKING CASTER

FOOT-CAST4
Load Rating (Per Set of 4): 1,320 lbs



PLATE CASTER

FOOT-CAST4-PLATE
Load Rating (Per Set of 4): 1,500 lbs



HEAVY DUTY PLATE CASTER

FOOT-CAST3-304SS
Load Rating (Per Set of 4): 800 lbs



STEM LEVELING CASTER

GDR-60S-X1/2 (IVORY) or GDR-60S-1/2-BLK*
Load Rating (Per Set of 4): 2,448 lbs



PLATE LEVELING CASTER

GDR-60F (IVORY) or GDR-60F-BLK*
Load Rating (Per Set of 4): 2,448 lbs



ANCHOR FOOT

FOOT-ANCHOR
Load Rating (Per Set of 4): 3,000 lbs



SUSPENSION CASTER

FOOT-CAST4-AV-PLATE
Load Rating (Per Set of 4): 880 lbs



HEAVY DUTY LEVELING CASTER

GDR-80S-1/2 (IVORY) or GDR-80S-1/2-BLK*
Load Rating (Per Set of 4): 4,900 lbs



HEAVY TOTAL LOCKING CASTER

FOOT-CAST2-HD
Load Rating (Per Set of 4): 3,600 lbs



LEVELER ANCHOR

FOOT-ANCHOR-LVLR

NOTE:

If you are requiring a foot option not listed, please reach out to see if we can help.

*These foot options are available in the colors ivory and black.

LEG OPTIONS

Manual Adjustable Legs



AL(1.5/2.0) 12
Load Rating (Per Set of 4): Matches Foot Option



Hand Crank Adjustable Legs



4M-12
Load Rating (Per Set of 4): 1,000 lbs



Electric Hydraulic Legs



4E-12
Load Rating (Per Set of 4): 1,000 lbs



FUME HOODS & LAB FIXTURES



FUME HOODS - PEGBOARDS/DRYING RACKS



UTILITY CHASE - REAGENT SHELVING - RACEWAYS



LAB GRADE FAUCETS - GAS VALVES - EYE WASH STATIONS - SINKS

IMPORTANT INFORMATION

CONTACT US

1112 Swenson Blvd, Elgin, Texas 78621 | (866) 612-7312

www.onepointesolutions.com | info@onepointesolutions.com

NATIONWIDE SERVICE

Our projects can be found in: New York, Chicago, Los Angeles, San Antonio, Dallas, Houston, Atlanta, Cheyenne, Des Moines, San Diego, Washington DC, San Francisco, Nashville, Honolulu, and just about everywhere else. Want to view a reference project in your area? Just ask!

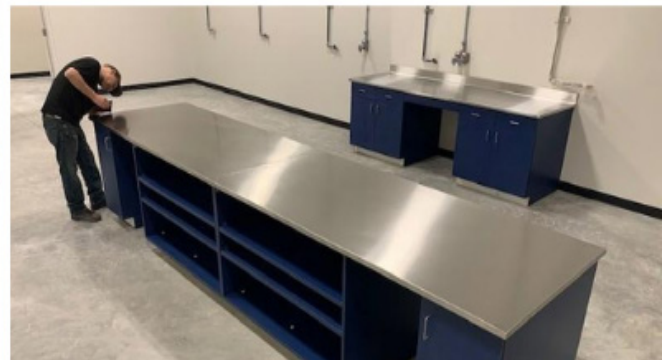

NOTES

NOTES

ONEPOINTE SOLUTIONS



(866) 612-7312

www.onepointesolutions.com