



To: Durcon Customers

206 Allison Drive  
Taylor, TX 76574  
PH: 512.595.8000  
www.durcon.com

Ref: RFQ (Quote Requests)

Our Estimating department is completely dependent upon you, the customer, to provide us with complete and accurate information. Below are some guidelines and information that is required in order for us to provide an accurate timely return of your pricing request.

**Solid Surface described as** – acrylic resins, fire-retardant fillers and proprietary coloring agents that are homogeneous, with uniform color throughout their thickness. Does not include *Quartz or Granite*.

Material Size – Solid surface is 1/2" Thick with standard sheet size of 144"x30".

*\*1/4" Thick Material is available in limited colors and sizes.*

### 1. Filled Out RFQ Form -

Please fill out the Durcon RFQ form with as much information as possible. All of the information requested on the form is important in order to provide accurate pricing. \*There is a section specific to solid surface as well.

Solid Surface	Base Bid	Alternate 1	Alternate 2
Brand:			
Color:			
Integral Sinks or Sink Cut Outs:			
Include these Items:			

- a. Brand – there are multiple Solid Surface brands (Wilsonart, Corian, Formica, etc..), and pricing varies greatly between them.
- b. Color – with-in each brand, the color or color group can vary in price. Depending on the color, movement patterns require extra material and fabrication. If multiple colors are required, further breakdown of each, can be provided in the “Special Instructions” or in the body of the email.
- c. Integral Sinks – please comment on if Solid Surface Integral Sinks are required, or if we only need to account for Cutouts (sinks provided by others. Ex: stainless steel sinks). If integral sink are required provide size and/or model number.
- d. Include these Items – note any specific items/needs to be included (Tops, Window Sills, Shelving, etc..)

### 2. Minimum 3-Day Return

We ask that you give us a minimum of 3 days to return pricing.

### 3. Provide Drawings and Specifications that Pertain to Material Requested for Pricing Only

In order to return your RFQ back in a timely fashion, please only provide the drawings and specifications that are needed for the take-off of the material requested, in-lieu of sending the entire project files.

#### **4. Drawing Pages and/or Room Numbers**

Providing Only the Pages Pertaining to Requested Pricing, Required Page Numbers, and Room Numbers Required If Possible.

#### **5. Special Instructions and/or notes:**

If there are any special instructions (phasing, exclusions, etc...) please provide that in the section on the RFQ form, or in the email. Also note if there are any particular requirements, such as Integral Curbs, Marine Edge, Non-Standard Edge (\*Ex: Bullnose), etc...

#### **6. Aprons**

If front aprons are required, if possible, please specify if they are to be integral or sent as loose pieces.

#### **7. Window Sills**

If possible, please provide an itemized list, locations, or marked up drawing of the required sills.

#### **8. Itemized Lists**

If sending itemized lists or descriptions with-out drawings, please be sure to provide all the information requested on the RFQ form, as well as –

- a. Length and Depth of all required tops.
- b. Edge thickness (solid surface material is ½" thick, edge thickness can be ½" and 1"+, \*¾" thick not available)
- c. Edge type – Standard is Eased
- d. Substrate requirement – type (Standard is MDF)
- e. Which/How Many Edges are finished
- f. Curbs – Height and which tops require them.
- g. Cutouts – What type and how many cutouts or router work is required.

#### **9. Typical Top Depth**

Standard is based on typical countertops 24"-25"Dp. with maximum 1-1/2" Eased Edge and 4" Tall Loose Curbs. Wider/Deeper tops require extra material and fabrication charges.

#### **10. Exclusions**

Durcon will exclude any "curved/thermo-formed" paneling, or items that need to be built/formed around millwork at time of fabrication.

#### **11. Freight/Packing**

If an "estimated freight" rate is required, please include delivery location. Any project with integral sinks requires extra packing materials and crating.

206 Allison Drive  
Taylor, TX 76574  
PH: 512.595.8000  
www.durcon.com

Ref: Shop Drawings

Our Drafting department is totally dependent upon you, the customer, to provide us with complete and accurate Shop Drawings. We cannot make assumptions in trying to interpret what is needed. Our Drafting department is presently experiencing some delays due to the quality of drawings we are now receiving. These delays may in return cause delays in fabrication and delivery. To help prevent these delays, Durcon has created a set of guidelines and an example drawing.

The following guideline and example drawing explain what Durcon needs on all shop drawings. The information is very important and necessary for us to make a quality product to your specification.

## **Drafting Requirements**

The first thing our Drafters do is to review all of the documents in the job folder such as the quote, e-mails, purchase order and other revisions. Their objective is to learn everything there is to know about the project before they begin drafting the shop tickets.

It is important that you understand that each piece of material has its own shop ticket for identification. Our drafting system is a custom program. The Drafters enter information for each piece into the data fields and AutoCAD automatically draws the piece ticket. This is why it is so important that you provide us with the final information on all shop drawings based on the following rules.

## **Standard Rule Set for Specifying Solid Surface Tops**

### **1. Use Top Dimensions**

Top details should be the overall top dimensions including any overhangs or fillers required. Top dimensions must be final field verified dimensions and should measure up with the cabinet elevations (please provide elevations with final shop drawings if available).

### **2. Provide Top Description**

Include Brand, Color and Thickness of tops and curbs (for tops, the edge/overall thickness)

(Ex: "Wilsonart, 9092MG Black Onyx Mirage, 1/2" Thick" - 1-1/2" Thick Countertops, 1/2" Thick Curbs)

### **3. Edge Detail**

Provide an edge detail showing the edge finish (eased, bevel, radius, etc...), and the drop edge build up.

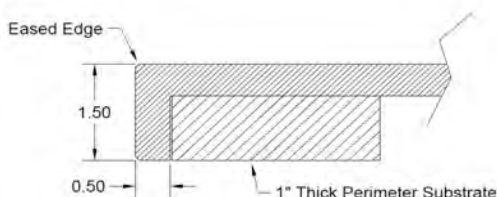

#### 4. **Substrate Details**

What type of wood substrate is required (Ex: MDF, MEDEX, Fire Grade, etc..) and the thickness of the substrate. At each location/top, specify if a “Full” or “Ladder/Perimeter” substrate is required.

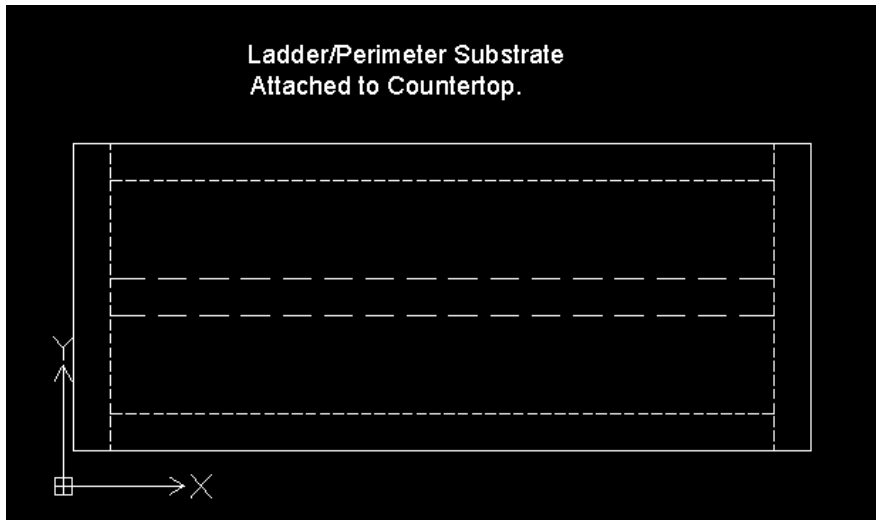

#### 5. **Verify Field Conditions**

Wall to wall dimensions must be verified and indicate if allowance for top joints is included.

#### 6. **Size and Locate All Cutouts**

Specify cutout sizes and if the cutout should be finished. Cutouts with radius corners must also be indicated and detailed. When specifying for Durcon, please locate from left to right and front to back to the centerline of the cutouts.

#### 7. **Integral Sinks**

If sinks are to be integral solid surface, specify the model number. When specifying the location, please locate from left to right and front to back, to the centerline of the sink.

#### 8. **Details on Special Cutouts**

Show degree of angles, length, width and center of arcs (especially on belly cuts), etc.

#### 9. **Indicate Locations of Finished Edges and Butt Joints**

This is especially important with peninsula tops or any tops requiring a finish and a butt joint along the same edge.

#### 10. **Provide Section Views and Elevations**

It helps to understand the application especially when dealing with high/low situations on wall runs and islands. Our Drafters look for detail on each piece of solid surface that goes through our plant. Each piece has its own identity.

#### 11. **Curbs/Splash**

Specify if Curbs/Splash are to be “Loose” or “Integral” (Integral splash only at back, ends will be loose).  
(all splash will be ½” thick).

#### 12. **Other**

Provide hole sizes, quantities; quantity, length, Aprons (Integral or Loose?), Shelving, etc.

## **Standard Rule Set for Specifying Top Joints**

### **1. *Never Interfere With knee spaces***

Always look out for the end user. Never interfere with writing or sit-down areas.

### **2. *Minimum to Cutout***

Place seams no closer than 3" from any sink, cooktop cutout or dishwasher.

### **3. *Maximum Length***

Durcon will draw joints to maximum length, or best yield, unless drawings include joint locations or specify that top joints match cabinet joints. Recommended Maximum Fabricated Length is 120". (*Optimal Yield lengths – 72", 48", 36"*)

### **4. *Factory Seams***

Any top over 30" wide, will require a factory seam. Seam will be inconspicuous, not invisible. Depending on the color, movement patterns will have a visible seam with possible change of direction of the pattern.

### **5. *Optimize Saw Time***

Durcon will use maximum work surface lengths if joint locations are not provided.

### **6. *Provide Elevations***

Cabinet elevations are helpful for Durcon to determine the best placement of top joints.

### **7. *Joint Allowance***

No Joint Allowance will be applied.

# Example Layout

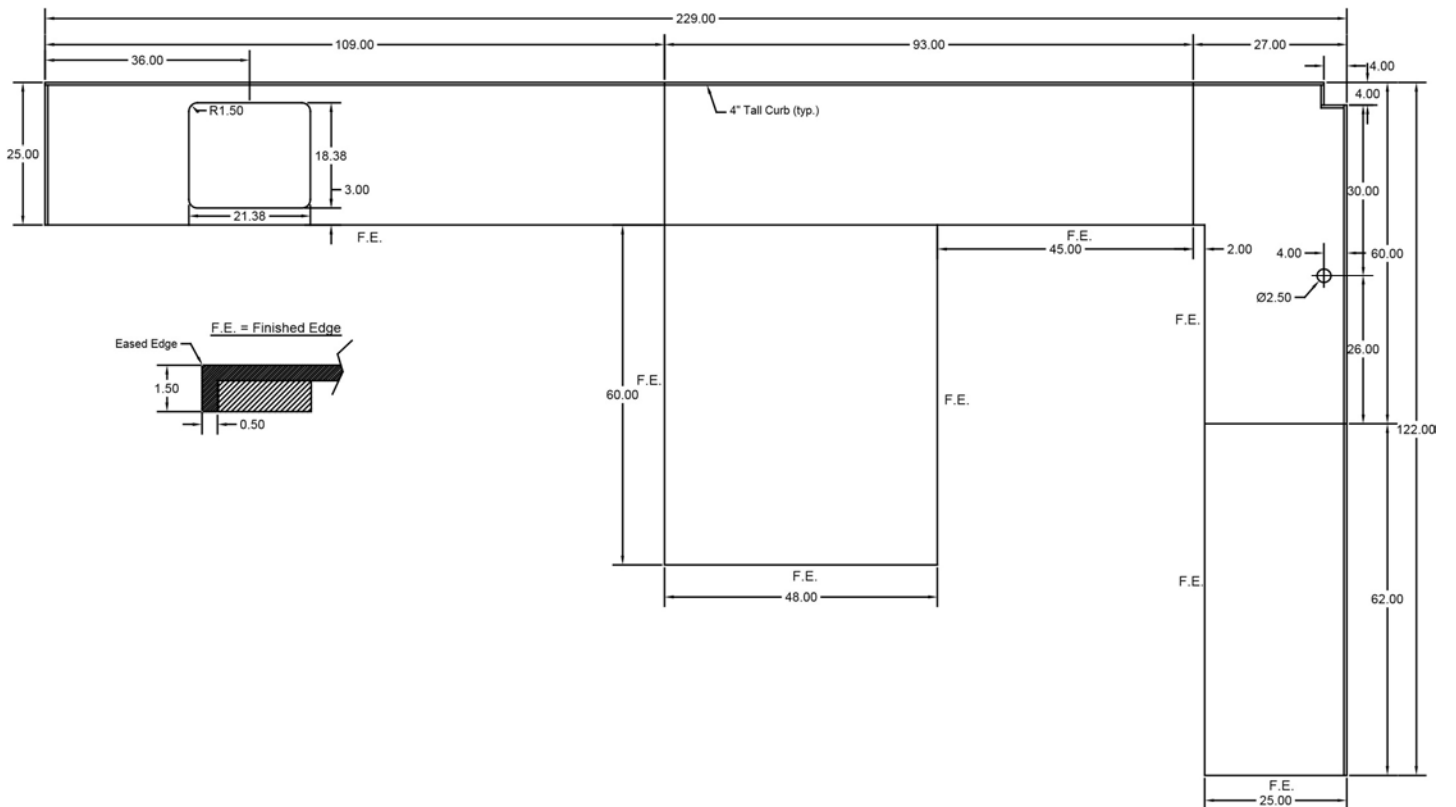
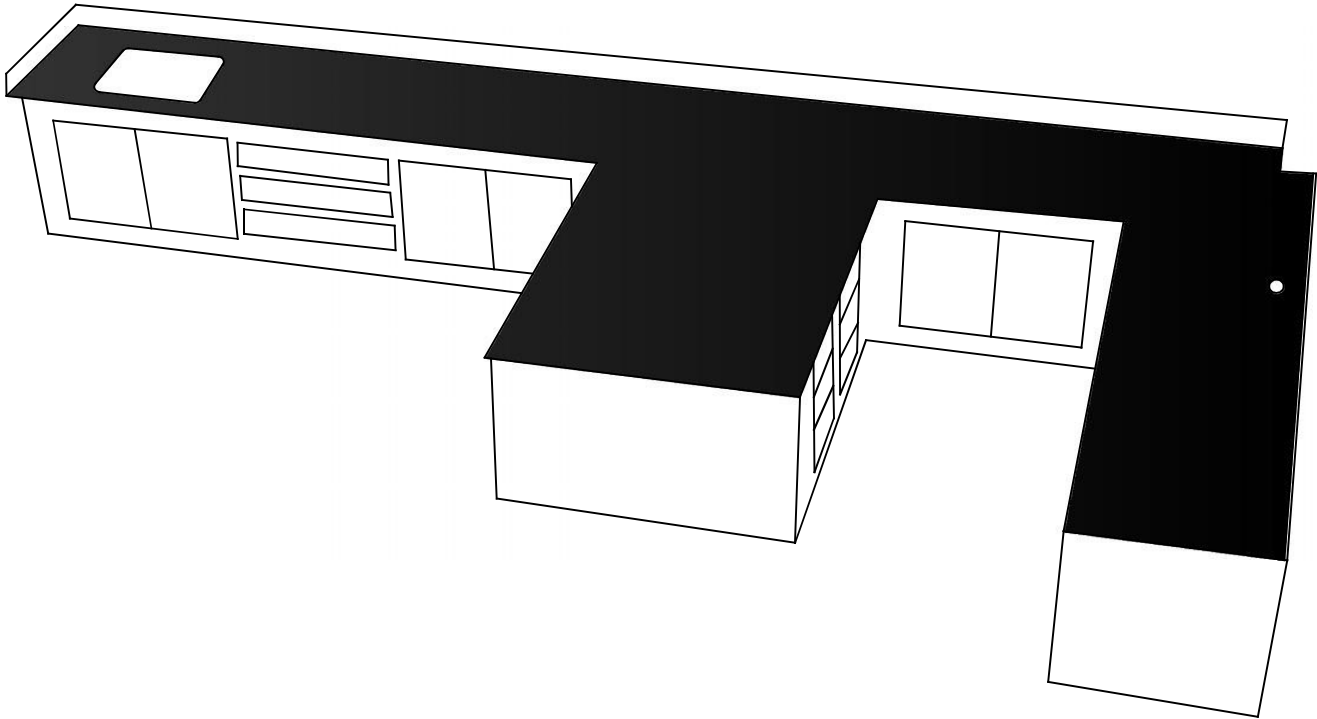

**Standard Edge Finishes -**

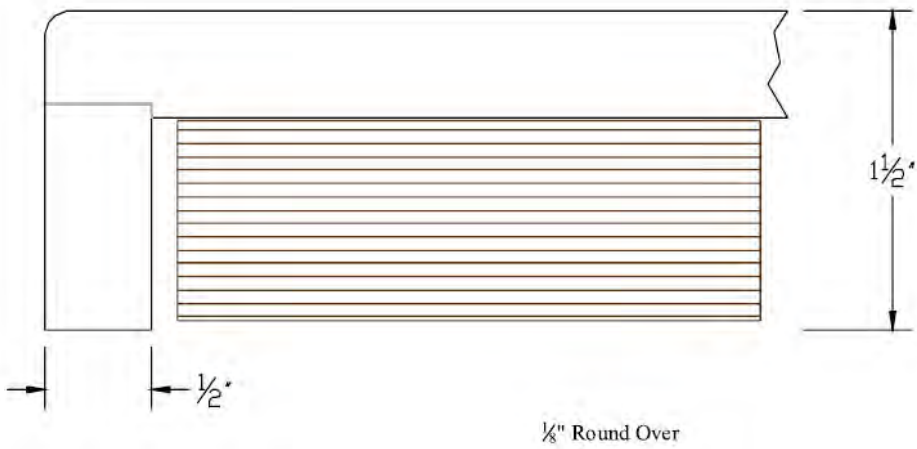
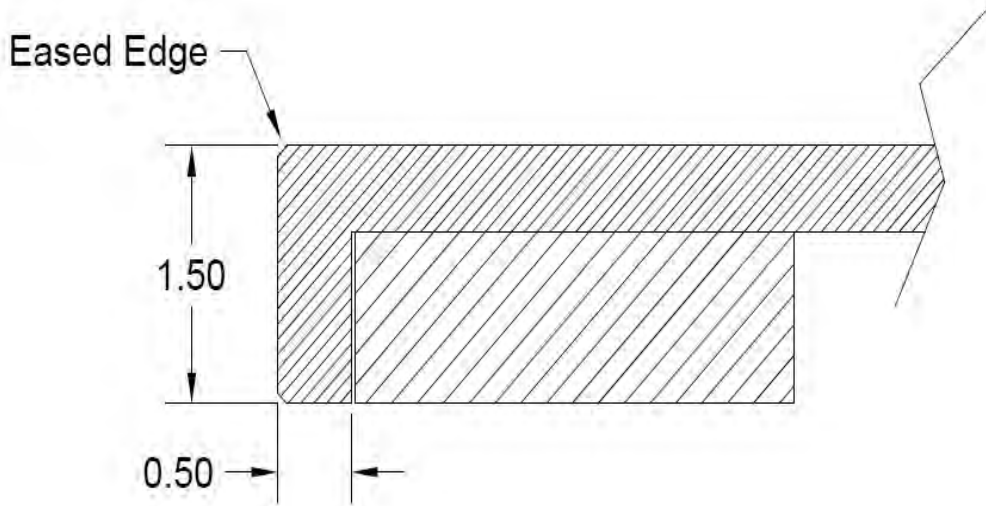

**Optional Edge Finishes (Additional Charges May Apply) -**

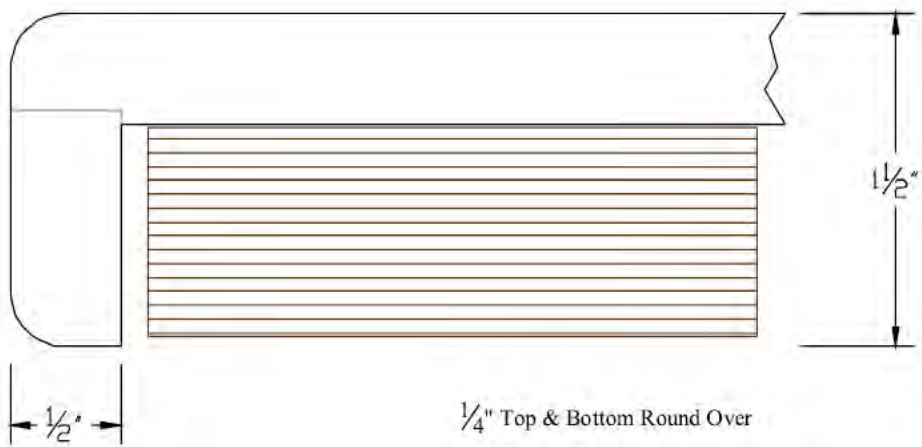
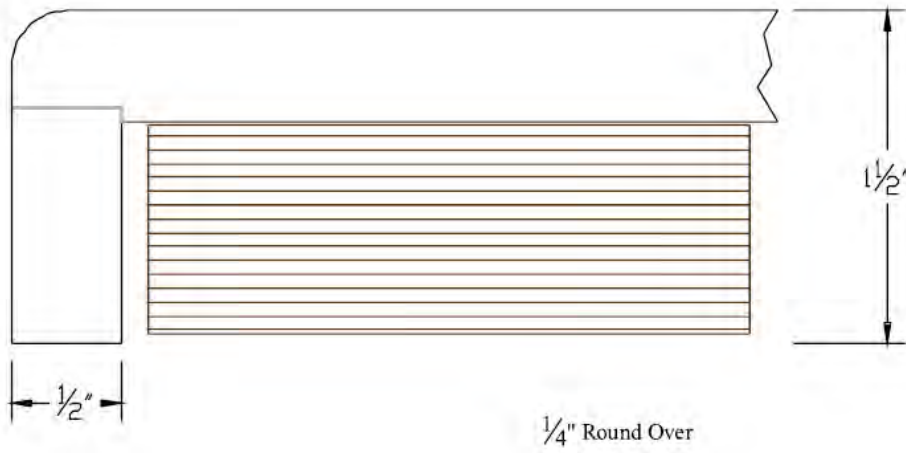
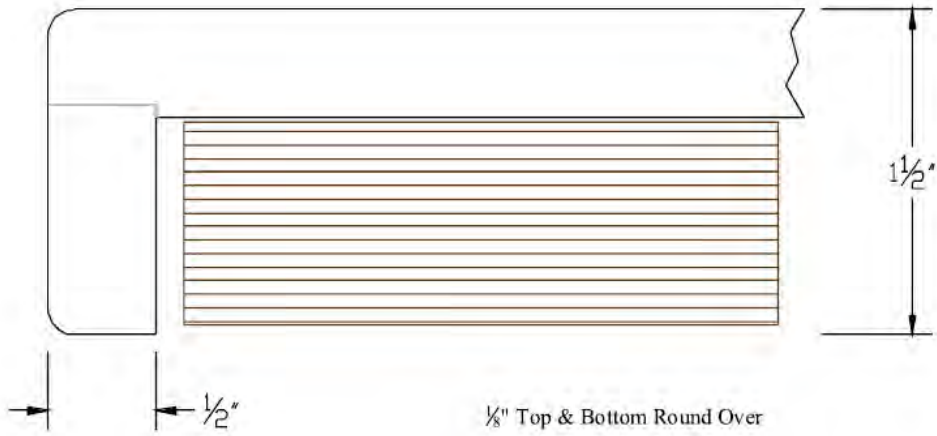



**Premium Edge Finishes (Additional Charges Apply) -**

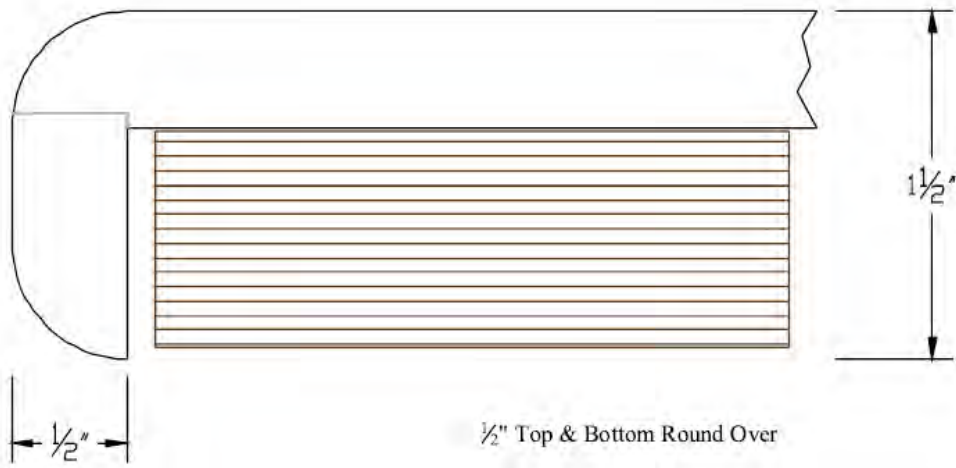
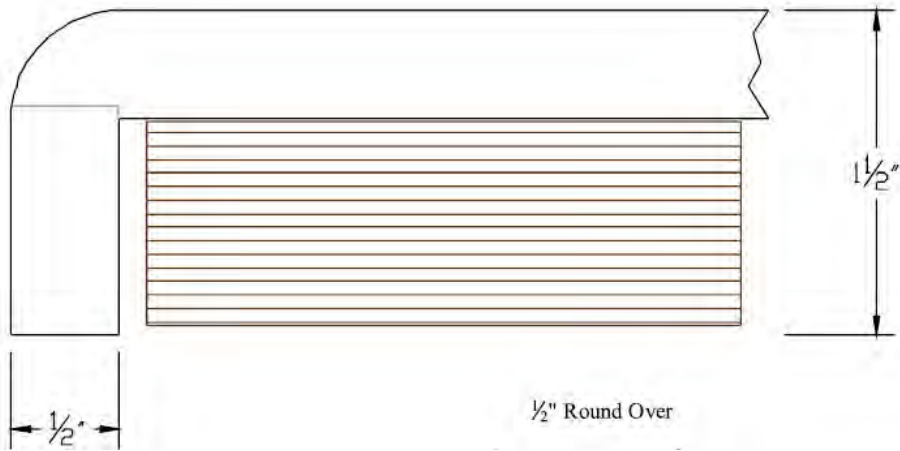

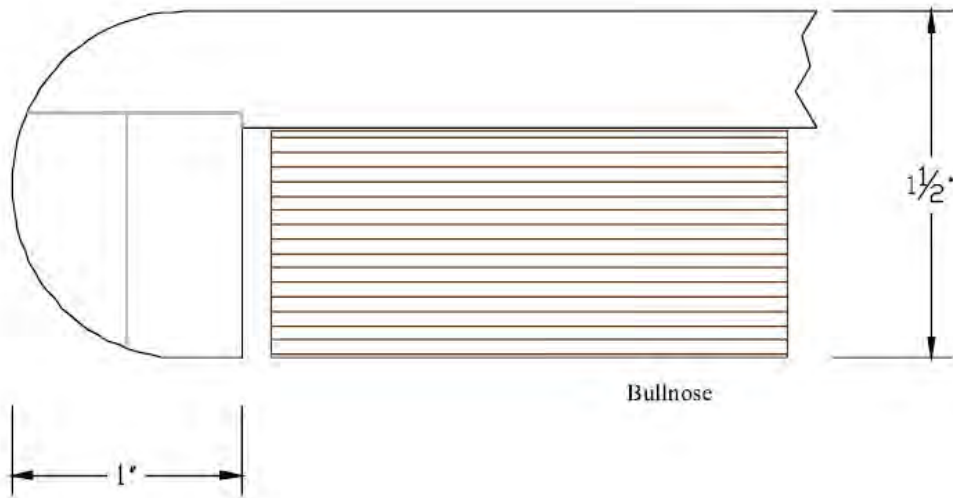
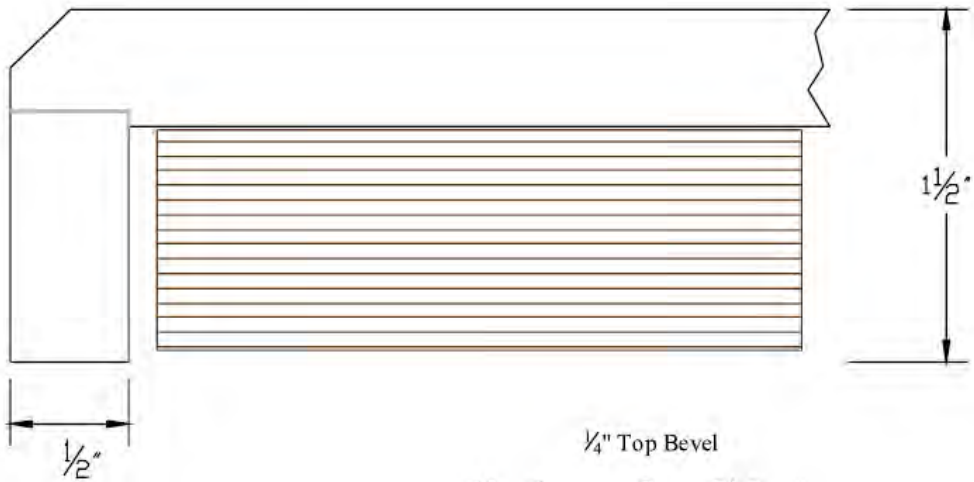

**Non-standard Details and Requirements –**

- 1. Waterfall Edges** - Legs/Panels that extend down from the countertop to the floor, will be supplied loose, for field trimming and seaming. Please provide a detail with all necessary information (width, height, thickness, etc..).

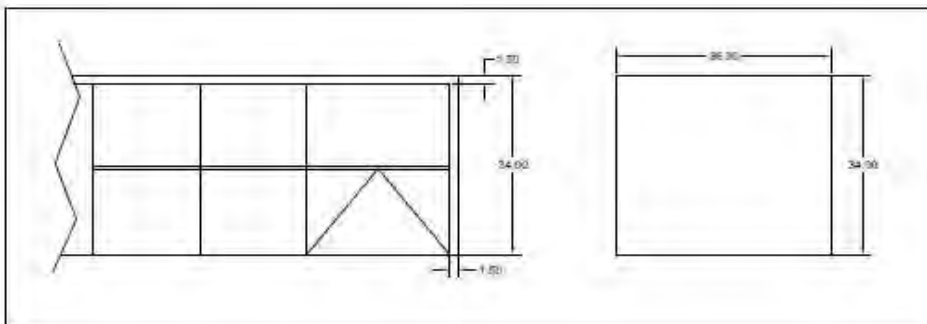

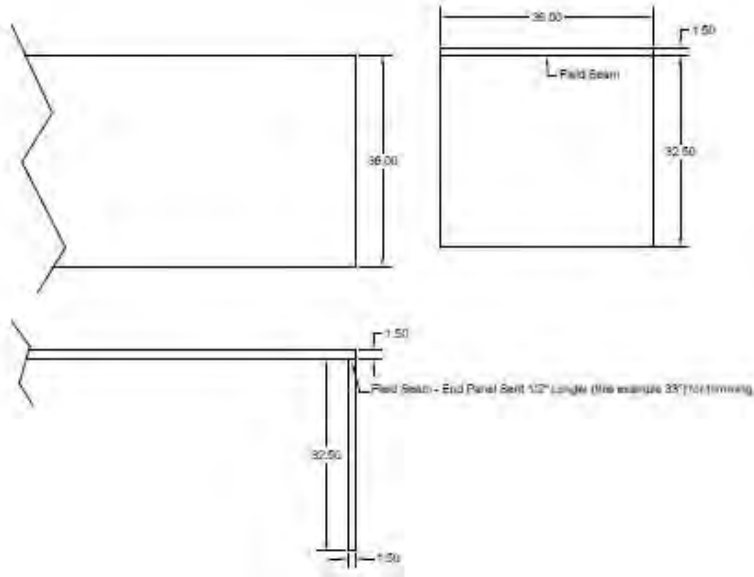

2. **Integral/Coved Curb** – Integral Curbs can be provided at “back” edges (side/end splash will be loose) for an added cost. Note on each top/elevation if/where integral curbs are required.

