

## UNCRATING AND INSTALLATION INSTRUCTIONS

1. REMOVE PLASTIC WRAP.
2. REMOVE FOUR SCREWS (TWO EACH SIDE) AT TOP OF HOOD SIDE PANEL. REMOVE SIDE PANEL BY LIFTING UP.

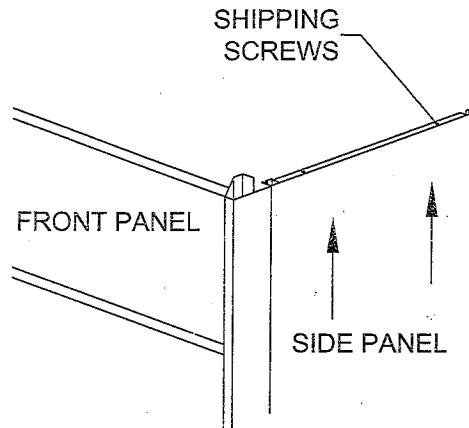

3. REMOVE FOUR SCREWS (TWO EACH SIDE) AT FRAME BOTTOMS, DETACHING HOOD FROM SKID.
4. REMOVE SHIPPING SCREWS FROM BACK OF FLUORESCENT LIGHT.
5. AT REAR OF HOOD, GRASP BOTH CABLES AND PULL DOWN TO LIFT SASH. DO NOT LIFT SASH WITHOUT PULLING CABLES.
6. BLOCK SASH IN OPEN POSITION AND REMOVE SASH WEIGHT FROM SKID. ATTACH WEIGHT TO CABLES USING THE SCREWS PROVIDED.
7. MOVE SASH UP AND DOWN TO BE SURE THE SASH IS WORKING FREELY.
8. LIFT HOOD ONTO THE COUNTER TOP USING AN APPROPRIATE HOOD LIFTER AND/OR MANPOWER. DO NOT LIFT HOOD BY SIDE PANEL MOUNTING RAILS.

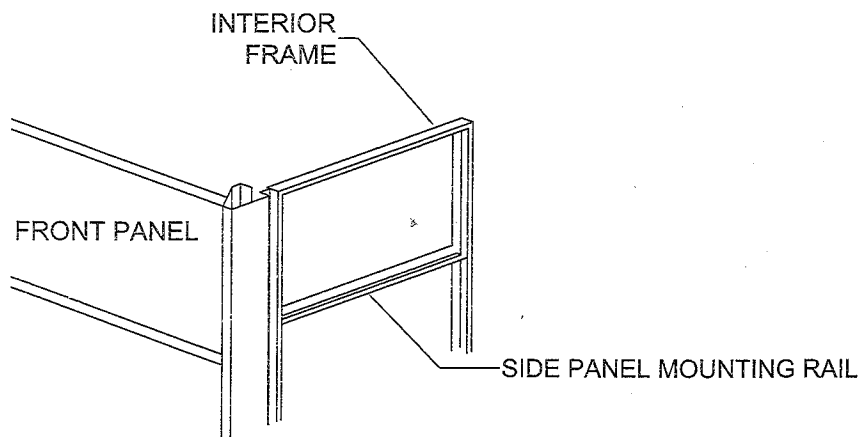

9. CONNECT DUCTWORK, PLUMBING AND ELECTRICAL AS REQUIRED.
10. REPLACE SIDE PANELS BY POSITIONING THE PANEL SLIGHTLY ABOVE IT'S FINISHED POSITION AND SLIDING IT DOWN TO ENGAUGE THE SIDE PANEL CLIPS WITH THE SIDE PANEL MOUNTING RAILS.

SASH STOP IS GRAVITY OPERATED. THE BOTTOM IS DESIGNED TO CATCH ON THE FINGER PULL OF THE SASH FRAME

BE SURE TO SET THE SASH AT THE HEIGHT YOU WISH IT TO STOP - THEN MARK THE MOUNTING HOLE TO BE DRILLED BY PLACING STOP IN POSITION AND MARKING MOUNTING HOLE ON FUME HOOD

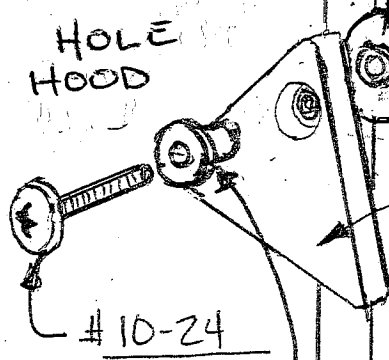

LARGE SHOULDER WASHER

NUT

DRILL HOLE

SASH STOP

