

ONEPOINTE SOLUTIONS

LABORATORY | INDUSTRIAL | COMMERCIAL

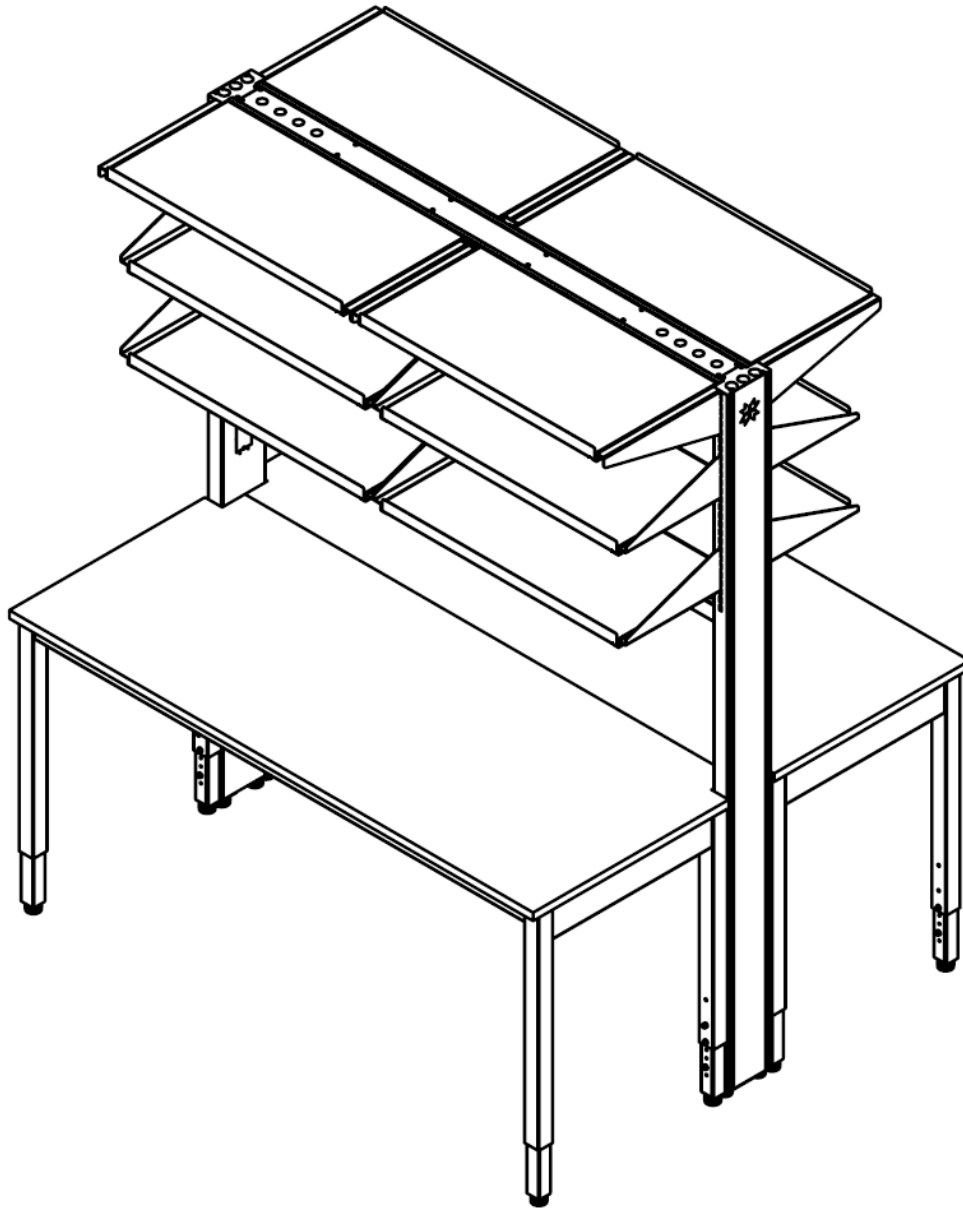

FLEX SYSTEMS

AN INFORMATIONAL GUIDE FOR
OUR UNIVERSAL LABORATORY WORKSTATION.

Table of Contents

SKU Charts	2
FLEX System Bundles	
• FLEX Base Bundle	3
• FLEX Raceway Bundle	4
• FLEX Plumbing Bundle	5
• FLEX Max Bundle	6
FLEX System Width Options	6
FLEX System Bundle Features	7
• UL Verified Raceways	
<i>(FLEX Raceway Bundle Only)</i>	
• WSF Kits & Hoses	8
<i>(FLEX Plumbing & Max Bundle Only)</i>	
• Ceiling Panels & Shelves	10
<i>(All FLEX Bundles)</i>	
Cabinet Accessories	
• Suspended Cabinets	14
• Mobile Cabinets	18
• Handles & Pulls	22
Finishes & Additional Accessories	
• Powder Coat Options	23
• Additional Accessories	23
• Work Surfaces	24
Contact & Nationwide Service	25

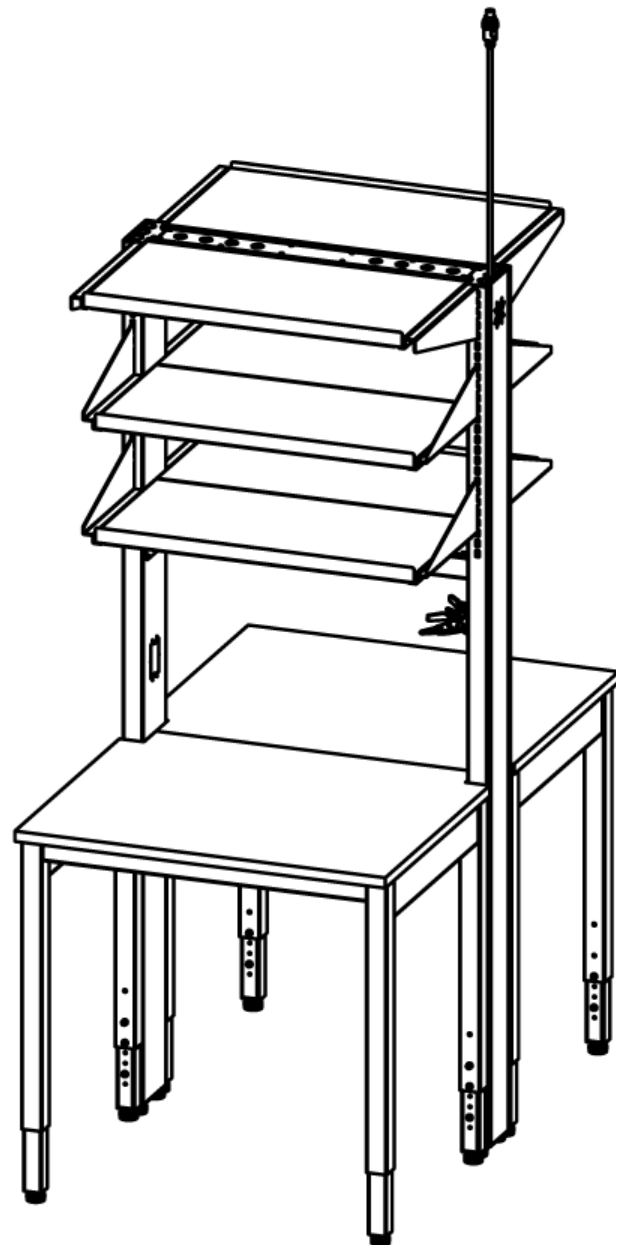

FLEX Systems

CATEGORY	WIDTH (in), WW	DEPTH (in) DS/SS	BUNDLE	HOSE LENGTH	FLUID TYPE	# OF SHELVES
FLEX	36", 42", 48", 54", 60" 66", 72", 84", 96"	30" - Single-Sided (SS) 60" - Double-Sided (DS)	BASE = BASE	N/A	N/A	1, 2, 3
	36", 42", 48", 54", 60" 66", 72", 84", 96"	30" - Single-Sided (SS) 60" - Double-Sided (DS)	RACEWAY = RWCY	N/A	N/A	1, 2, 3
	36", 42", 48", 54", 60" 66", 72", 84", 96"	30" - Single-Sided (SS) 60" - Double-Sided (DS)	PLUMBING = PLUM	84", 96"	Helium, Air, Cold Water, Vacuum, Gas, Argon, Nitrogen, Other	1, 2, 3
	36", 42", 48", 54", 60" 66", 72", 84", 96"	30" - Single-Sided (SS) 60" - Double-Sided (DS)	MAX = MAX	84", 96"	Helium, Air, Cold Water, Vacuum, Gas, Argon, Nitrogen, Other	1, 2, 3

Suspended Cabinet

CATEGORY	HEIGHT (in), HH	WIDTH (in), WW	DEPTH (in), DD	DRAWERS	DOORS	LOCKING	PULLS
SUS	03", 06", 09", 12", 15", 18", 21", 24",	15", 18", 21", 24", 30", 36", 42", 48"	20", 22"	0 to 5	0 to 2 *L,R	X = Locking Skip for no locks	A = Aluminum Pull W = Wire Stainless Pull

*Doors: L = Left hinge, R = right hinge, skip for double doors

Mobile Cabinet

CATEGORY	HEIGHT (in), HH	WIDTH (in), WW	DEPTH (in), DD	DRAWERS	DOORS	LOCKING	PULLS
MOB	23", 26", 29", 32',	15", 18", 21", 24", 30", 36", 42", 48"	20", 22"	2 to 5	1 to 2 *L,R	X = Locking Skip for no locks	A = Aluminum Pull W = Wire Stainless Pull

*Doors: L = Left hinge, R = right hinge, skip for double doors

Examples

FLEX-60SS-PLUM84-AIR-3

FLEX Plumbing Bundle with a width of 60", single-sided with an 84" hose for air and 3 shelves.

SUS-213622-02X-W

Suspended cabinet with 21" H x 36" W x 22" D, 0 Drawers, 2 Doors, Locking, Wire Stainless Steel Pull

MOB-211222-11RX-W

Mobile cabinet with 21" H x 12" W x 22" D, 1 Drawer, 1 Door Right-Hinged, Locking, Wire Stainless Steel Pull

Base Bundle

SKU: FLEX-WWDS/SS-BASE-1,2,3

Features

- (0 to 3) Rows of Shelves, Undermount Top Shelf
- Undershelf Light Compatible
- Knockout Piece for Data Provisions on Upright
- Single or Double Sided Assembly
- Perfect for Island Configuration
- Heavy Duty Construction
- Upright Assembly & Accepts All Upright Components
- Adjustable Shelving
- Height Adjustable Work Surface
- Adaptable Design
- Made with 2" Tube Steel
- Perfect for Mobile Storage



**Knockout Data
Piece**

Out of our FLEX Bundles, the FLEX Base bundle is the simplest form of a FLEX system that you can achieve. You can keep it as is or use it to build out the FLEX system you desire. It comes with a height adjustable work surface, shelving, and single or double-sided assembly.

Unlike other tables, our FLEX systems can have a work surface on both sides of a shared upright tower, allowing you to maximize your environment and save space.

Made in America, built to be long-lasting, and SEFA certified, you can design and customize, our Base FLEX system to fit your lab.

CONFIGURATIONS OPTIONS

HEIGHT	WIDTH	DEPTH	SHELF DEPTH	# of SHELVES
84"	36", 42", 48", 54", 60", 66", 72", 84", 96"	30" (SS) 60" (DS)	13", 16"	1,2,3

Raceway Bundle

SKU: FLEX-WWDS/SS-RCWY-1,2,3

Features

- (0-3) Rows of Shelves; Undermount Top Shelf
- Undershelf Light Compatible
- UL Approved Raceways
- Knockout Piece for Data Provisions on Upright
- Single or Double Sided Assembly
- Perfect for Island Configuration
- Heavy Duty Construction
- Upright Assembly & Accepts All Upright Components
- Adjustable Shelving
- Height Adjustable Work Surface
- Adaptable Design
- Made with 2" Tube Steel
- Perfect for Mobile Storage



Raceway



Knockout Data Piece

The Raceway FLEX Bundle is ideal when you need a flexible workbench for just electrical purposes. For every FLEX in the bundle, it comes with a corresponding UL verified raceway, providing you with confidence when it comes to electrical integrations.

In addition, like all of our FLEX system bundles, the Raceway FLEX Bundle comes with a height adjustable work surface, shelving and single or double sided assembly. Unlike other tables, this system can have a work surface on both sides of a shared upright tower, allowing you to maximize your environment and save space.

Made in America, built to be long-lasting, and SEFA certified, you can design and customize, our Raceway FLEX system to fit your lab.

CONFIGURATIONS OPTIONS

HEIGHT	WIDTH	DEPTH	SHELF DEPTH	# of SHELVES
84"	36", 42", 48", 54", 60", 66", 72", 84", 96"	30" (SS) 60" (DS)	13", 16"	1,2,3

Plumbing Bundle

SKU: FLEX-WWDS/SS-PLUM84/96-FLUIDTYPE-1,2,3

Features

- (0-3) Rows of Shelves; Undermount Top Shelf
- Undershelf Light Compatible
- (1) Air/Cold Water/Gas/Vacuum/Helium/Other/Argon/Nitrogen WSF Kit
 - Blade Handle Ball Valve
 - PVC Hose (Stainless Steel Hose for Gas and Nitrogen)
 - Quick Connects
- Max of (3) Valves Can Fit on FLEX Bundle
- Knockout Piece for Data Provisions on Upright
- Single or Double Sided Assembly
- Perfect for Island Configuration
- Heavy Duty Construction
- Upright Assembly & Accepts All Upright Components
- Adjustable Shelving
- Height Adjustable Work Surface
- Adaptable Design
- Made with 2" Tube Steel
- Perfect for Mobile Storage



PVC Hose

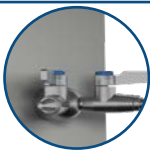

Valve



Knockout Data Piece

When you need fluid services attached to your lab bench the Plumbing FLEX Bundle works best. Each comes with a WSF kit customized to fit your selected fluid(s) options including helium, nitrogen, cold water, and more.

In addition, like all of our FLEX system bundles, the Plumbing FLEX Bundle comes with a height adjustable work surface, shelving and single or double sided assembly. Unlike other tables, this system can have a work surface on both sides of a shared upright tower, allowing you to maximize your environment and save space.

Made in America, built to be long-lasting, and SEFA certified, you can design and customize, our Plumbing FLEX system to fit your lab.

CONFIGURATIONS OPTIONS

HEIGHT	WIDTH	DEPTH	HOSE LENGTH	FLUID TYPE	SHELF DEPTH	WORK SURFACE
84"	36", 42", 48", 54", 60", 66", 72", 84", 96"	30" - (SS) 60" - (DS)	84", 96"	Air, Argon, Cold Water, Gas, Helium, Nitrogen, Vacuum, Other	13", 16"	1,2,3

Max Bundle

SKU: FLEX-WWDS/SS-MAX84/96-FLUIDTYPE-1,2,3

Features

- (0-3) Rows of Shelves; Undermount Top Shelf
- Undershelf Light Compatible
- (1) Air/Cold Water/Gas/Vacuum/Helium/Other/Argon/Nitrogen WSF Kit Included:
 - Blade Handle Ball Valve
 - PVC Hose (Stainless Steel Hose for Gas and Nitrogen)
 - Quick Connects
- Max of (3) Valves Can Fit on FLEX Bundle
- UL Verified Raceway
- Knockout Piece for Data Provisions on Upright
- Single or Double Sided Assembly
- Perfect for Island Configuration
- Heavy Duty Construction
- Upright Assembly & Accepts All Upright Components
- Adjustable Shelving
- Height Adjustable Work Surface
- Adaptable Design
- Made with 2" Tube Steel
- Perfect for Mobile Storage

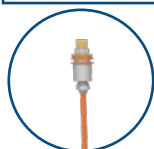

PVC Hose

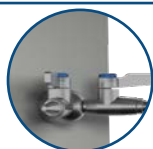

Valve

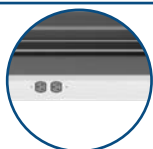

Raceway



Knockout Data Piece

The Max FLEX bundle is the combination of both our Raceway and Plumbing FLEX bundles. It comes with UL verified raceways, and a WSF kit configured to your selected fluid(s).

Made in America, built to be long-lasting, and SEFA certified, you can design and customize, our Max FLEX system to fit your lab.

CONFIGURATIONS OPTIONS

HEIGHT	WIDTH	DEPTH	HOSE LENGTH	FLUID TYPE	SHELF DEPTH	# OF SHELVES
84"	36", 42", 48", 54", 60", 66", 72", 84", 96"	30" - (SS) 60" - (DS)	84", 96"	Air, Argon, Cold Water, Gas, Helium, Nitrogen, Vacuum, Other	13", 16"	1,2,3

Width Options

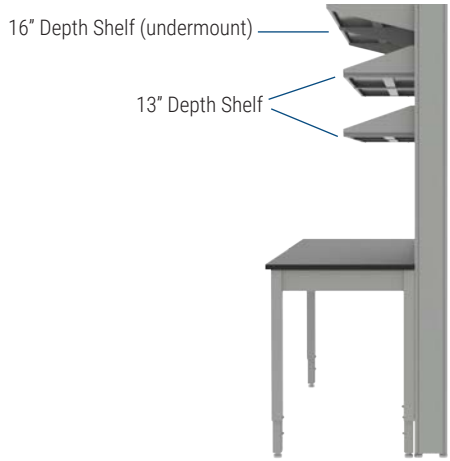

SINGLE-SIDED

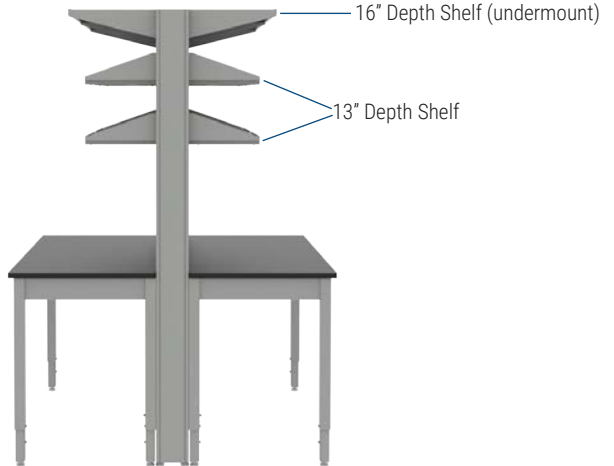

DOUBLE-SIDED



36" WIDTH



42" WIDTH



48" WIDTH



54" WIDTH



60" WIDTH



66" WIDTH



72" WIDTH



84" WIDTH

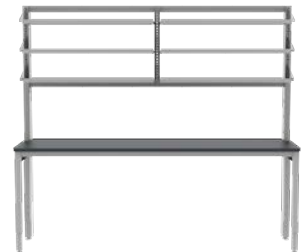

96" WIDTH

Raceways

Single-Sided Single Circuit PS130 Raceways

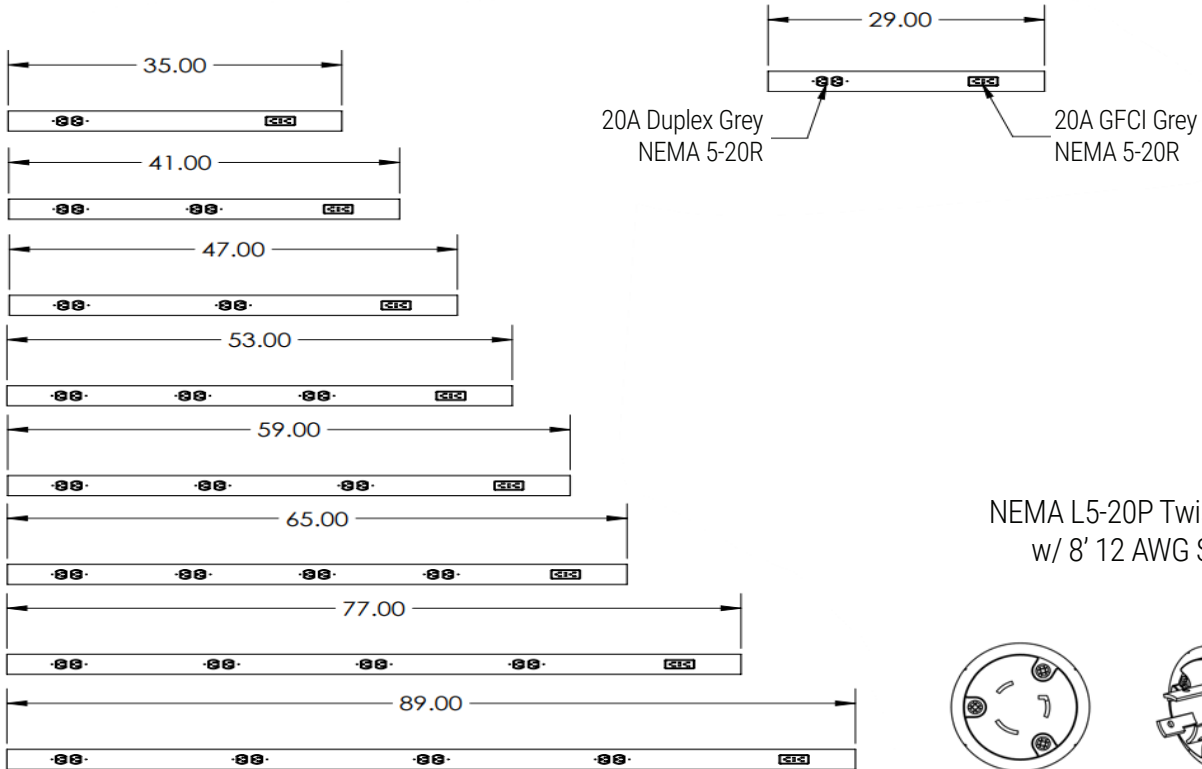

SINGLE-SIDED FLEX WIDTH	RACEWAY SKU	RACEWAY LENGTH	# OF CIRCUITS	# OF DUPLEX CIRCUITS	# OF GFCI OUTLETS
36"	FXPWR-36SS-1C1D1G	29"	1	1	1
42"	FXPWR-42SS-1C1D1G	35"	1	1	1
48"	FXPWR-48SS-1C2D1G	41"	1	2	1
54"	FXPWR-54SS-1C2D1G	47"	1	2	1
60"	FXPWR-60SS-1C3D1G	53"	1	3	1
66"	FXPWR-66SS-1C3D1G	59"	1	3	1
72"	FXPWR-72SS-1C4D1G	65"	1	4	1
84"	FXPWR-84SS-1C4D1G	77"	1	4	1
96"	FXPWR-96SS-1C4D1G	89"	1	4	1

Raceways

Double-Sided Double Circuit PS130 Raceways

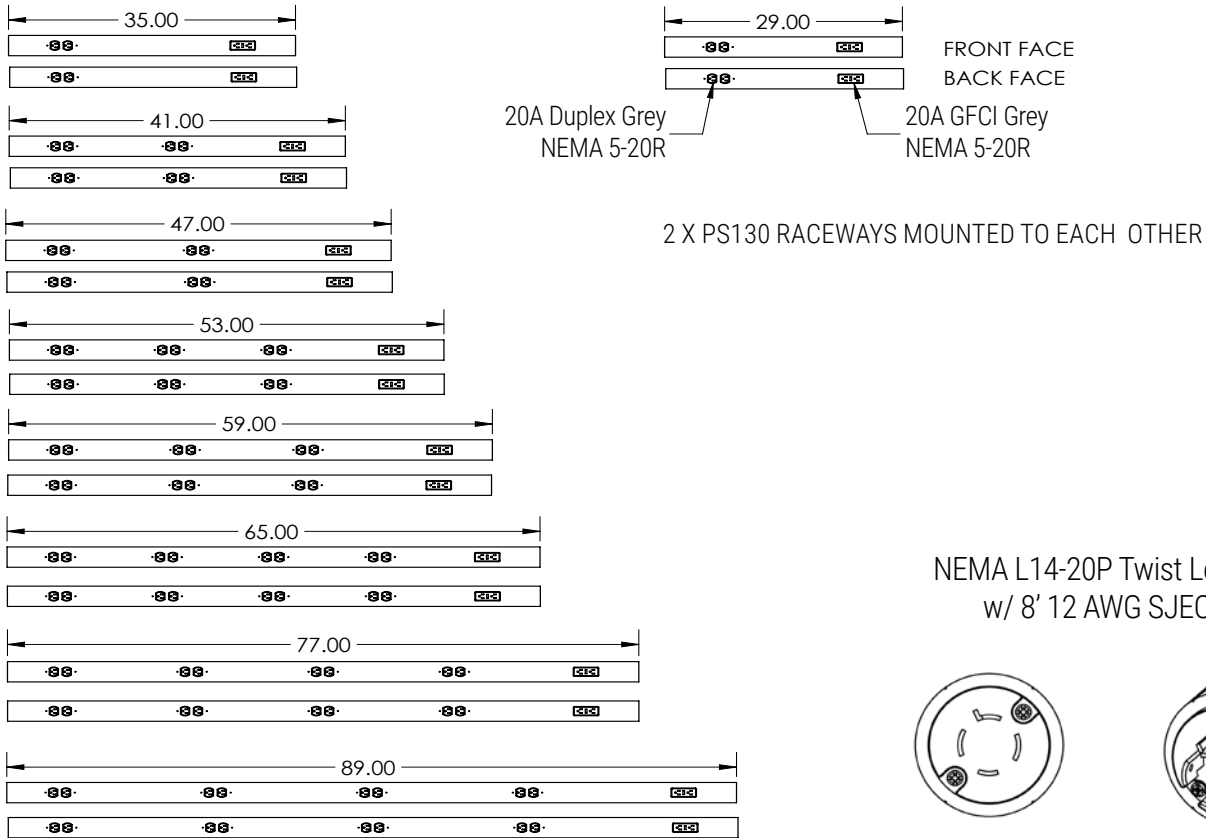

DOUBLE-SIDED FLEX WIDTH	RACEWAY SKU	RACEWAY LENGTH	# OF CIRCUITS	# OF DUPLEX OUTLETS/SIDE	# OF GFCI OUTLETS/SIDE
36"	FXPWR-36DS-2C2D2G	29"	2	1	1
42"	FXPWR-42DS-2C2D2G	35"	2	1	1
48"	FXPWR-48DS-2C4D2G	41"	2	2	1
54"	FXPWR-54DS-2C4D2G	47"	2	2	1
60"	FXPWR-60DS-2C6D2G	53"	2	3	1
66"	FXPWR-66DS-2C6D2G	59"	2	3	1
72"	FXPWR-72DS-2C8D2G	65"	2	4	1
84"	FXPWR-84DS-2C8D2G	77"	2	4	1
96"	FXPWR-96DS-2C8D2G	89"	2	4	1

WSF Plumbing

Full Assembly

Quick Connect Body

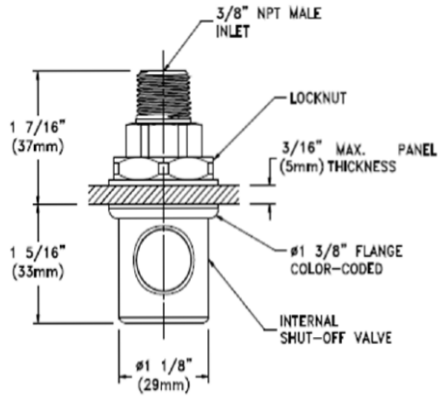

Quick Connect Plug

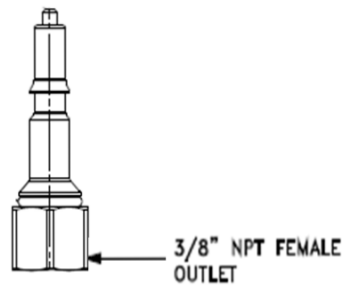

Hose

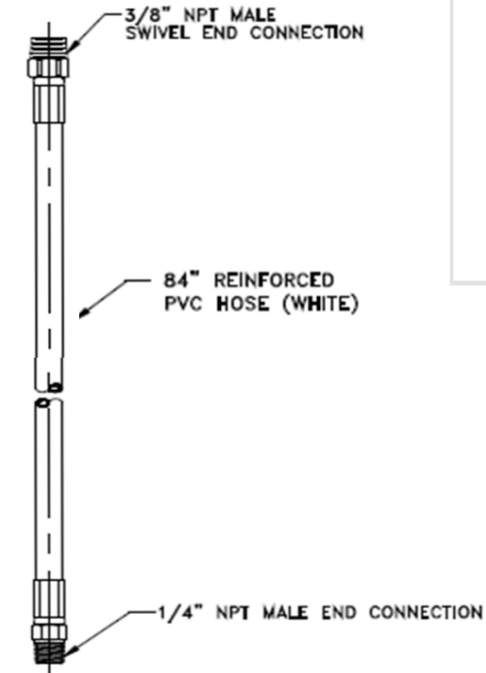

Valve

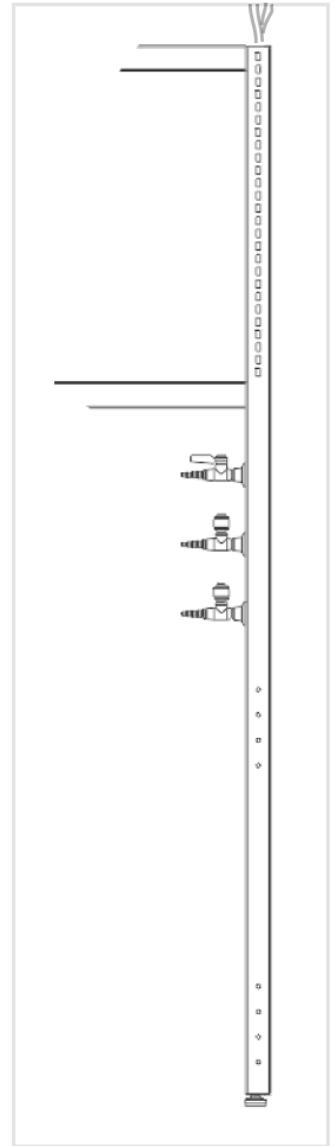
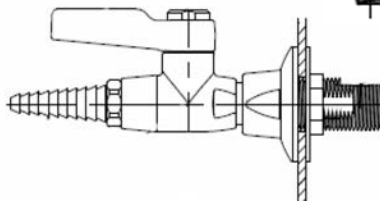

FLEX UPRIGHT WITH VALVES

WSF Plumbing

Plumbing Service Add-On

FXWSF - BBDS/SS - AIR - 84/96

FLEX WSF Category Type of Valve, Double Sided/Single Sided

Type of Fluid

Hose Length

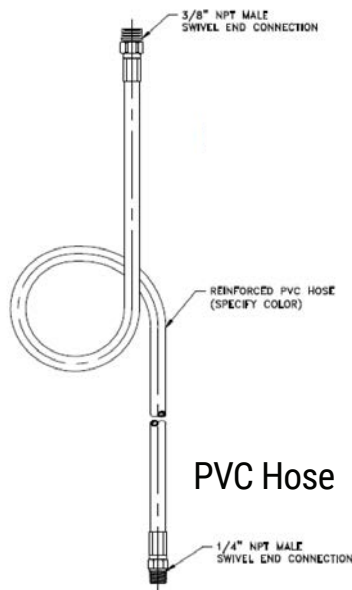

PVC Hose

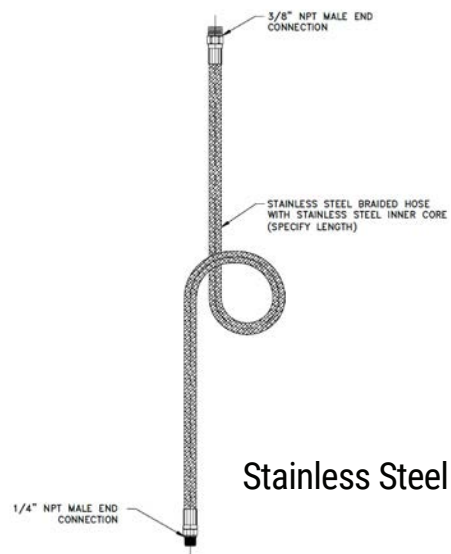

Stainless Steel Hose

CATEGORY	VALVE TYPE	DEPTHS (in) DS/SS	FLUID TYPE	HOSE LENGTH
FXWSF	<ul style="list-style-type: none"> • BBSS: Blade Handle Ball Valve (Single-Sided) • BBDS: Blade Handle Ball Valve (Double-Sided) • RNSS: Round Handle Needle Valve (Single-Sided) • RNDS: Round Handle Needle Valve (Double-Sided) 	30" - Single-Sided (SS) 60" - Double-Sided (DS)	Helium, Air, Cold Water, Vacuum, Gas, Argon, Nitrogen, Other	84", 96"

Example

FXWSF-BBSS-COLD WATER-96

FLEX Plumbing Service Add-On, with a ball valve, single-sided with a 96" PVC hose for cold water.

NOTE: For Gas and Nitrogen, a stainless steel hose will be used.

WSF Plumbing

Valves

Needle Valves

INV010-16-14BV-158

Furnished with BI637-01-14R
used with single-sided FLEX

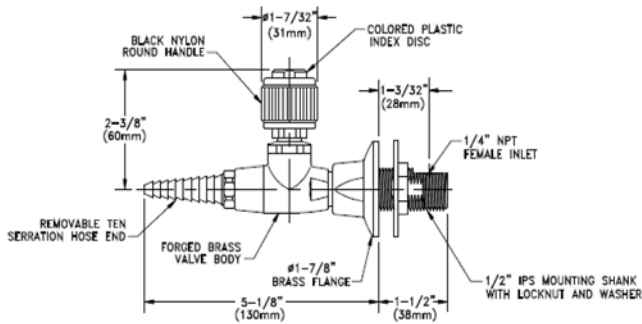

INV010-16-14BV-141

Furnished with BI637-02-04R
used with double-sided FLEX

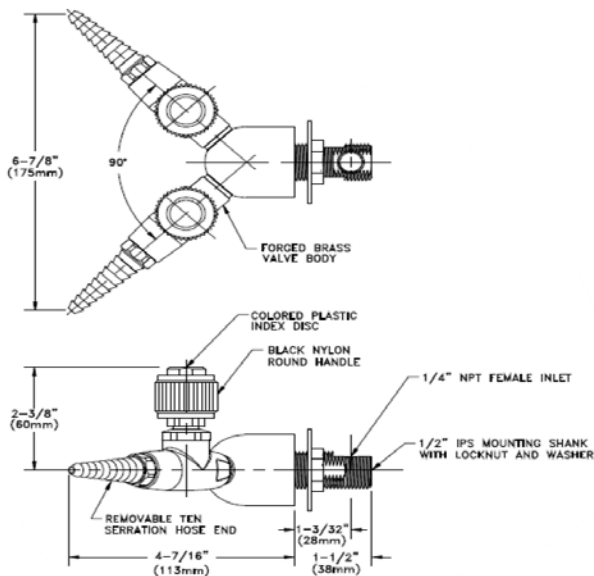

Ball Valves

L4200-158

Furnished with BI637-01-14R
used with single-sided FLEX

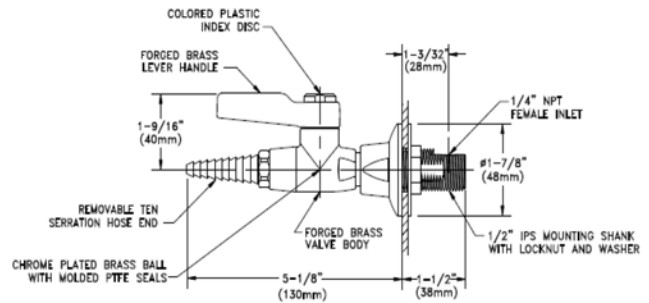

L4200-141

Furnished with BI637-02-04R
used with double-sided FLEX

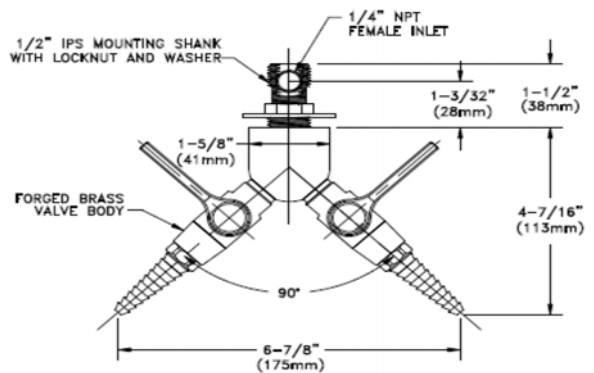

Color Guide For Fluids

K1 - Black - Helium	K5 - Blue - Gas
K2 - Orange - Air	K6 - White - Other
K3 - Green - Cold Water/ Water/ H2O	K7 - Violet - Argon (shown as purple sometimes)
K4 - Yellow - Vacuum	K8 - Brown - Nitrogen

Ceiling Panels & Shelves

Ceiling Panels Add-On

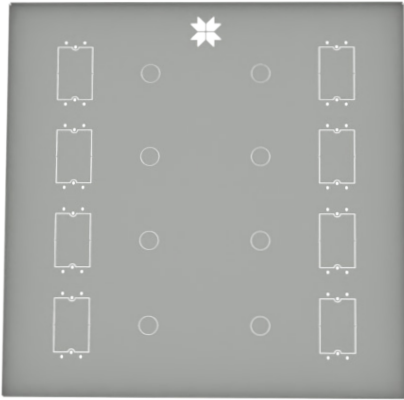

FXCP-WW-DD

Features

- Comes With Every FLEX System Regardless of Configuration
- Can be Shared by (2) Adjacent FLEX Systems
- Holds Maximum of (4) Plumbing Services & (4) Electrical Connections per FLEX System Shared
- Sits on Ceiling Grid
- Pre-Drilled Holes Available

CONFIGURATION OPTIONS

WIDTHS	DEPTHS
24"	12", 24"

Shelves Add-On



FXSAS-DS/SS-WWDD-UANG/ANG-PCS

CONFIGURATION OPTIONS

DOUBLE/SINGLE-SIDED	DEPTHS
DS/SS	13", 16"

CONFIGURATION CHART

FLEX WIDTH	13" SHELF DEPTH	16" SHELF DEPTH
36"	3613	3616
42"	4213	4216
48"	4813	4816
54"	2713D	2716D
60"	3013D	3016D
66"	3313D	3316D
72"	3613D	3616D
84"	4213D	4216D
96"	4813D	4816D

FLEX systems with widths of 54" or above, (2) shelves will be added to complete a row. Represented by "D" in the chart.

Suspended Cabinets

SKU: SUS-HHWWDD-L/RX-A/W

Features

- 18 GA Sheet Metal Construction
- Soft-Closing Drawers and Doors
- 1x Adjustable Shelf (Doors)
- Concealed Hinges
- Heavy-Duty Construction
- Powder Coated-Metal or Stainless Steel
- Customizable Drawer/Door Fronts



Sometimes you need direct access to a cabinet without having to leave your work area. That's where our suspended cabinets come into play.

Our suspended cabinets are designed to be fastened beneath the work surface of any of our lab tables. Once installed they are a solution that is very robust and becomes part of the table.

Suspended cabinets can be manufactured in cold-rolled powder-coated steel or 304 stainless steel to accommodate different area requirements. Designed to be long-lasting and SEFA certified, our suspended cabinets are the perfect addition for your workspace needs.

CONFIGURATION OPTIONS

HEIGHTS	WIDTHS	DEPTHS	DRAWERS
03", 06", 09", 12", 15", 18", 21", 24", 27"	15", 18", 21", 24", 30", 36", 42", 48"	20", 22"	0 TO 5
DOORS	DOOR HINGE	LOCKING	PULLS
0 TO 2	L = LEFT R = RIGHT SKIP FOR DOUBLE DOOR	X=LOCKING SKIP FOR NO LOCKS	A = ALUMINUM PULL W = WIRE STAINLESS PULL

CUSTOM SIZES AVAILABLE UPON REQUEST

AVAILABLE HEIGHTS ARE LISTED ABOVE CONFIGURATIONS

1 DRAWER

SUS-HHWDD-10-A/W



2 DRAWERS

SUS-HHWDD-20-A/W



3 DRAWERS

SUS-HHWDD-30-A/W

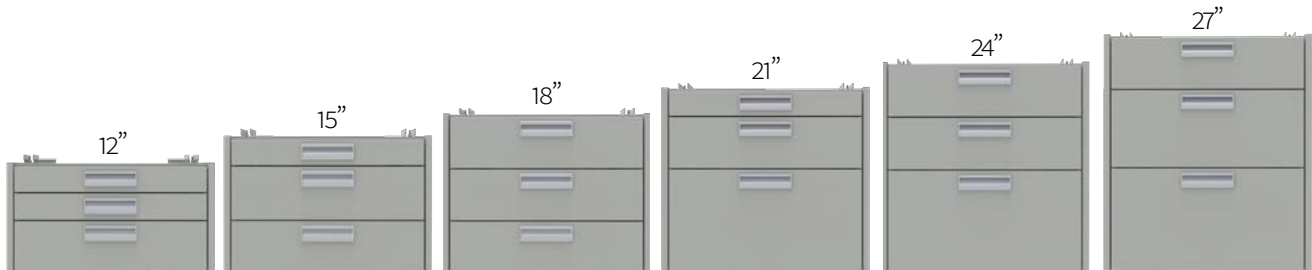

4 DRAWERS

SUS-HHWDD-40-A/W

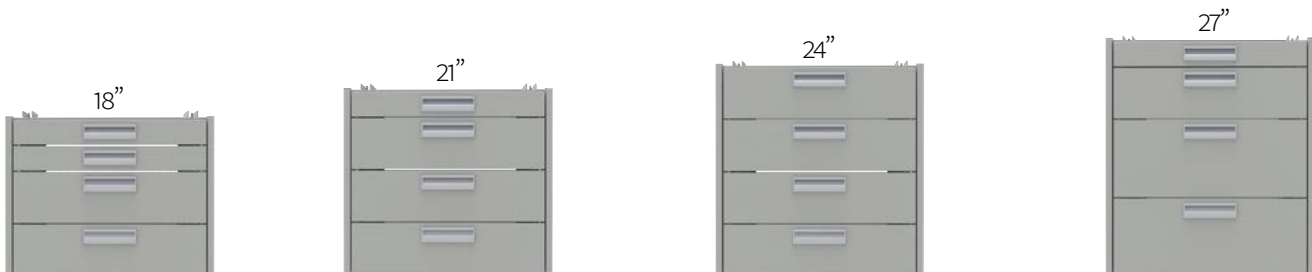

5 DRAWERS

SUS-HHWDD-50-A/W

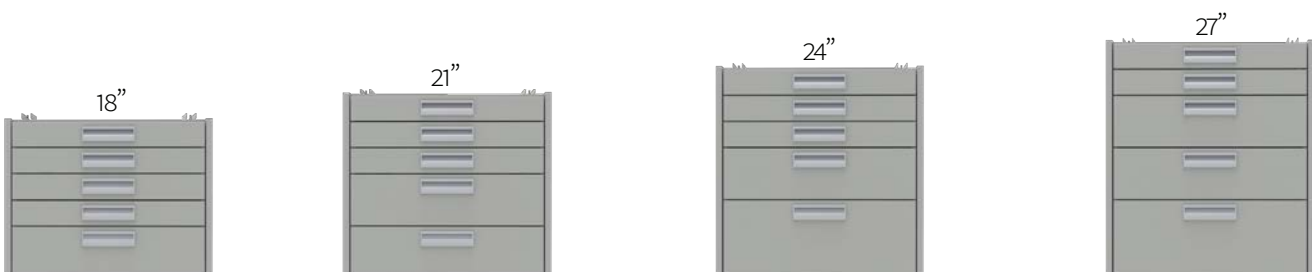

SUS-HHWDD-01L/R-A/W

SUS-HHWDD-02-A/W

1 DOOR

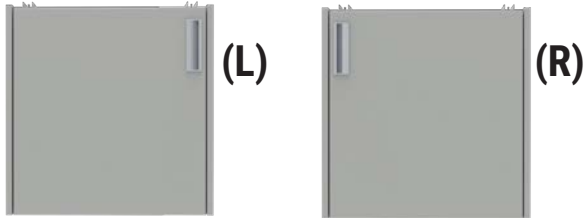

CABINETS WITH WIDTHS LESS THAN 30" WILL HAVE (1) DOOR.
AVAILABLE HEIGHTS: 18", 21", 24", 27"

2 DOORS



CABINETS WITH WIDTHS OF 30" OR MORE WILL HAVE (2) DOORS.
AVAILABLE HEIGHTS: 18", 21", 24", 27"

DUAL COMBINATIONS



AVAILABLE HEIGHTS:
18", 21", 24", 27"

SUS-HHWDD-11L/R-A/W



AVAILABLE HEIGHTS:
ALL

SUS-HHWDD-00



AVAILABLE HEIGHTS:
18", 21", 24", 27"

SUS-HHWDD-12-A/W



AVAILABLE HEIGHTS:
21", 24", 27"

SUS-HHWDD-22-A/W



Suspended Cabinet Compatibility

SUSPENDED CABINET SKU CHART	
SUSPENDED CABINET HEIGHT	SKU NUMBER
03"	SUS-03WWDD-R/LX-A/W
06"	SUS-06WWDD-R/LX-A/W
09"	SUS-09WWDD-R/LX-A/W
12"	SUS-12WWDD-R/LX-A/W
15"	SUS-15WWDD-R/LX-A/W
18"	SUS-18WWDD-R/LX-A/W
21"	SUS-21WWDD-R/LX-A/W
24"	SUS-24WWDD-R/LX-A/W
27"	SUS-27WWDD-R/LX-A/W

FLEX TABLE HEIGHTS	SUSPENDED CABINET HEIGHTS
30"	03", 06", 09", 12", 15", 18", 21", 24"
32"	03", 06", 09", 12", 15", 18", 21", 24", 27"
34"	03", 06", 09", 12", 15", 18", 21", 24", 27"
36"	03", 06", 09", 12", 15", 18", 21", 24", 27"

NOTE: FLEX system work surfaces are adjustable from 30"-36" in 2" increments.

FLEX TABLE WIDTHS	SUSPENDED CABINET WIDTHS
36"	15", 18", 21", 24", 30"
42"	15", 18", 21", 24", 30", 36"
48"	15", 18", 21", 24", 30", 36", 42"
54"-96"	15", 18", 21", 24", 30", 36", 42", 48"

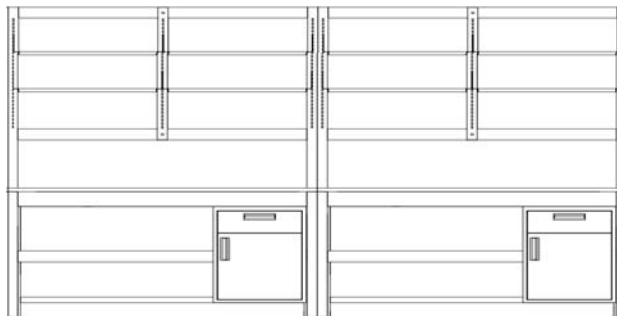

Mobile Cabinets

SKU: MOB-HHWWDD-L/RX-A/W

Features

- 18 GA Sheet Metal Construction
- Soft-Closing Drawers and Doors
- 1x Adjustable Shelf
- Plate Casters
- Standard 1" Metal Top or Lab Worksurface
- Anti-Tip Design
- Concealed Hinges
- Heavy-Duty Construction
- Powder Coated Metal, Stainless Steel or Plastic Laminate
- Customizable Drawer/Door Fronts



Whether your process requires it or if you just want to build the ultimate flexible lab, our mobile cabinets are a great solution. Furnishing your space with our mobile cabinets contributes to present-day adaptable and flexible space design techniques that are popular in any laboratory.

Mobile cabinets can be manufactured in cold-rolled powder-coated steel or 304 stainless steel to accommodate different area requirements. Designed to be long-lasting and SEFA certified, our suspended cabinets are the perfect addition to your workspace needs.

CONFIGURATION OPTIONS

HEIGHTS	WIDTHS	DEPTHS	DRAWERS
23", 26", 29", 32', 35"	15", 18", 21", 24", 30", 36", 42", 48"	20", 22"	0 TO 5
DOORS	DOOR HINGE	LOCKING	PULLS
0 TO 2	L = LEFT R = RIGHT SKIP FOR DOUBLE DOOR	X=LOCKING SKIP FOR NO LOCKS	A = ALUMINUM PULL W = WIRE STAINLESS PULL

CUSTOM SIZES AVAILABLE UPON REQUEST

HEIGHTS ARE LISTED ABOVE CONFIGURATIONS.
NOTE: HEIGHTS DO NOT ACCOUNT FOR THE 1" TOP THAT NEEDS TO BE SELECTED ON MOBILES.

2 DRAWERS

MOB-HHWDD-10-A/W



3 DRAWERS

MOB-HHWDD-30-A/W



4 DRAWERS

MOB-HHWDD-40-A/W



5 DRAWERS

MOB-HHWDD-50-A/W



MOB-HHWDD-01L/R-A/W

MOB-HHWDD-02-A/W

1 DOOR

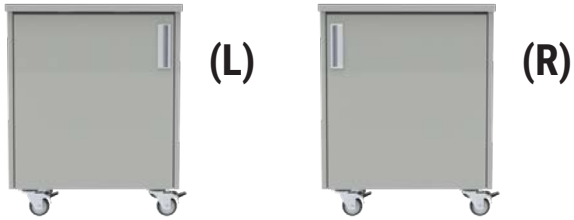

CABINETS WITH WIDTHS OF 24" OR LESS WILL HAVE (1) DOOR.

2 DOORS



CABINETS WITH WIDTHS OF 30" OR MORE WILL HAVE (2) DOORS.

DUAL COMBINATIONS



MOB-HHWDD-11L/R-A/W

AVAILABLE HEIGHTS:
ALL



MOB-HHWDD-12-A/W

AVAILABLE HEIGHTS:
26", 29", 32", 35"



MOB-HHWDD-22-A/W

AVAILABLE HEIGHTS:
26", 29", 32", 35"

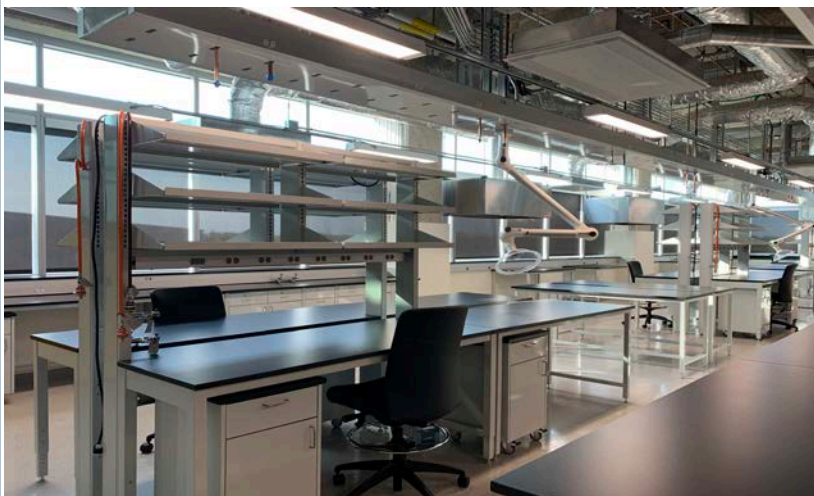

Mobile Cabinet Compatibility

MOBILE CABINET SKU CHART	
MOBILE CABINET HEIGHT	SKU NUMBER
23"	MOB-23WWDD-R/LX-A/W
26"	MOB-26WWDD-R/LX-A/W
29"	MOB-29WWDD-R/LX-A/W
32"	MOB-32WWDD-R/LX-A/W
35"	MOB-35WWDD-R/LX-A/W

FLEX TABLE HEIGHTS	MOBILE CABINET HEIGHTS
36"	23", 26", 29", 32"
34"	23", 26", 29"
32"	23", 26", 29"
30"	23", 26"

NOTE: FLEX system work surfaces are adjustable from 30"-36" in 2" increments.

FLEX TABLE WIDTHS	SUSPENDED CABINET WIDTHS
36"	15", 18", 21", 24", 30"
42"	15", 18", 21", 24", 30", 36"
48"	15", 18", 21", 24", 30", 36", 42"
54"-96"	15", 18", 21", 24", 30", 36", 42", 48"

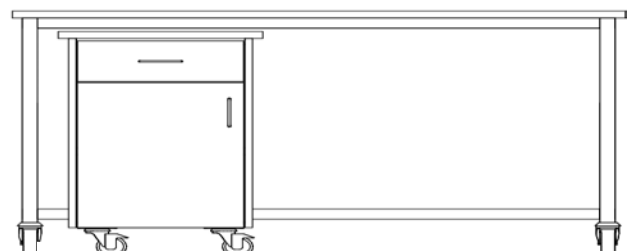
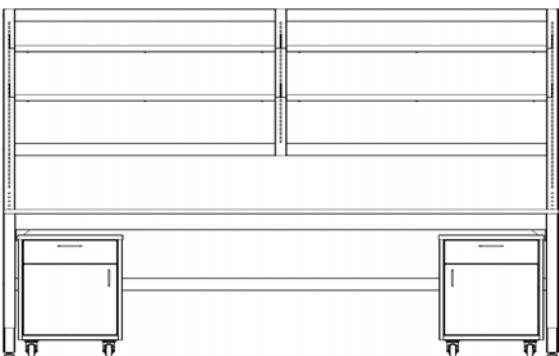

Stainless Steel Wire Pulls



Aluminum Recessed Handles

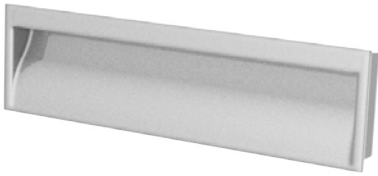

Powder Coat Options Available



Black Recessed Handles

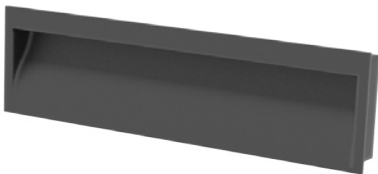

Custom Pull Options Available



Powder-Coat Options

RAL Colors



Non-Color Options*

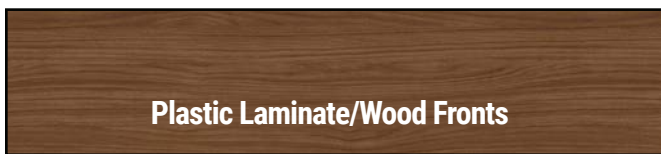

Plastic Laminate/Wood Fronts

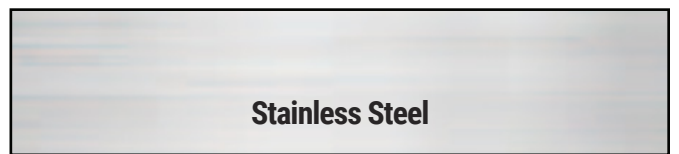

Stainless Steel

*Suspended & mobile cabinets only

Need a Custom Color?

Want a color you do not see? No worries we can help you get virtually any color for your casework. Let us know and we will do our best to get you virtually any color in the color wheel and even those that are not too. Our fabrications can be faced with a wide selection of hues and finishes, from bold to subdued. **Note: Available Upon Request; some colors may require a minimum order.**

Additional Accessories



MONITOR ARM



KEYBOARD TRAY



CPU HOLDER

Work Surface Options

Epoxy Resin



Black Onyx



Dark Khaki



Graphite



Grey



Lunar White



Tan

Epoxy resin is a quality material that is resistant to most chemicals, moisture, impact, and heat; it's the ideal solution for environments that are very corrosive or have a high level of moisture.

Note: Epoxy resin is a color-through material.

Phenolic Resin



Carbon Black



Durcon Graphite



Durcon Grey

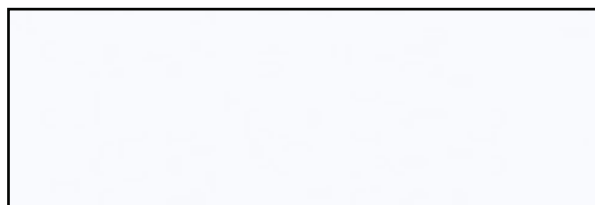

Glacier White



Steel Grey

Phenolic resin countertops and tabletops meet the requirements of most laboratories while including additional benefits such as chemical, wear, and water resistance.

Note: All phenolic resin countertops come with a black core regardless of color selected.

CONTACT US

1112 Swenson Blvd, Elgin, Texas 78621 | (866) 612-7312

www.onepointesolutions.com | info@onepointesolutions.com

NATIONWIDE SERVICE

Our projects can be found in: New York, Chicago, Los Angeles, San Antonio, Dallas, Houston, Atlanta, Cheyenne, Des Moines, San Diego, Washington DC, San Francisco, Nashville, Honolulu, and just about everywhere else. Want to view a reference project in your area? Just ask!



ONEPOINTE SOLUTIONS

(866) 612-7312

www.onepointesolutions.com