

FLEX SYSTEM ASSEMBLY - CUTSHEET

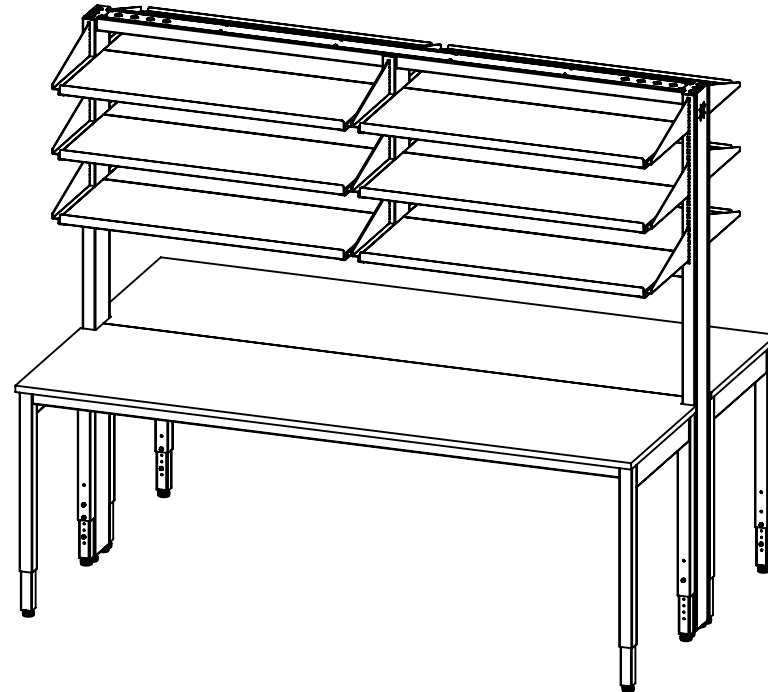
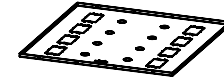

FEATURES -

- SHELVES : POWDER COATED 18GA COLD ROLLED STEEL.
- BRACKETS : POWDER COATED 12GA COLD ROLLED STEEL.
- SHELVES HAVE A LIP TO PREVENT ITEMS FROM ROLLING OVER THE EDGE.
- THE SHELVES ARE MOUNTED ON SLOTTED UPRIGHTS WHICH ALLOW FLEXIBILITY OF MOVING THE SHELF VERTICALLY IN 1 INCH INCREMENTS.
- EACH INDIVIDUAL SHELF HAS A WEIGHT CAPACITY OF 100LBS.
- THE SHELVES ARE HOOKED TO SLOTS SUCH THAT THEY PREVENT FROM FALLING OFF IN THE EVENT OF AN EARTHQUAKE.
- FLEX SYSTEM HAS THE ABILITY TO PROVIDE CONDUITS AND PORTS FOR ELECTRICAL POWER STRIPS, DATA CABLES AND PLUMBING.
- THIS INCLUDES A CEILING PANEL THAT HAS REMOVABLE KNOCKOUTS FOR POWER CORDS, PLUMBING TUBES, QUICK DISCONNECTS AND ELECTRICAL RECEPTACLES.
- THE TABLE HEIGHT CAN BE ADJUSTED FROM 30INCHES TO 36INCHES.
- THE TABLE CAN BE CONGIURED EITHER AS A SINGLE-SIDED TABLE OR A DOUBLE-SIDED TABLE.
- FLEX TABLES OF 54INCH WIDTH AND ABOVE HAVE TWO SHELVES FOR EACH ROW.

FLEX SYSTEM ASSEMBLY - 96 DOUBLE SIDED AS SHOWN IN PICTURE

SKU^s AVAILABLE FOR SUB-ASSEMBLIES TO COMPLETE THE SYSTEM -

- UPRIGHT+FRAME(s)
- COUNTERTOPS
- SHELVES
- CEILING PANEL (UPON CUSTOMER REQUEST)

ONEPOINTE SOLUTIONS

DRAWING DATE: 1/5/2021
DRAWN BY: DVEERSHETTY
TOLERANCE: ±.005 IN.
DO NOT SCALE DRAWING
ALL UNITS IN INCHES

PART # FLEX SYSTEM ASSEMBLY - CUTSHEET

DESCRIPTION: FLEX SYSTEM - CUTSHEET

MATERIAL:
GROUP:
REV: 20.05.01

FLEX SYSTEM ASSEMBLY - CUTSHEET
FLEX SYSTEM ASSEMBLY - 96 - DOUBLE SIDED

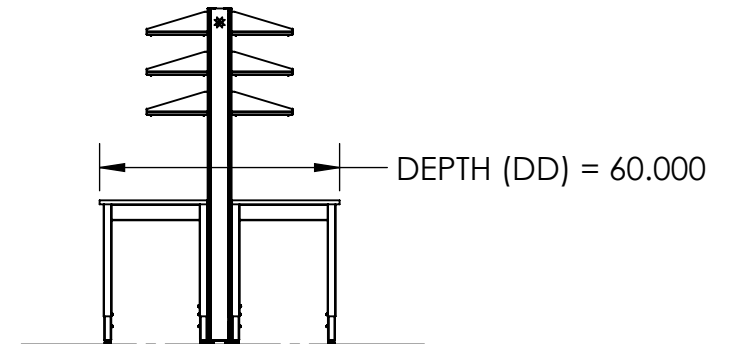
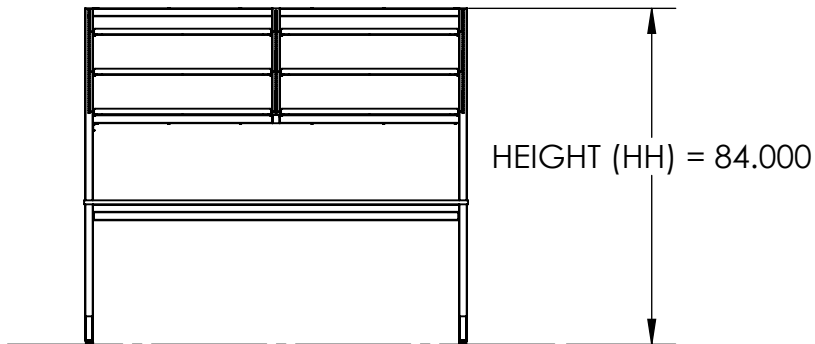
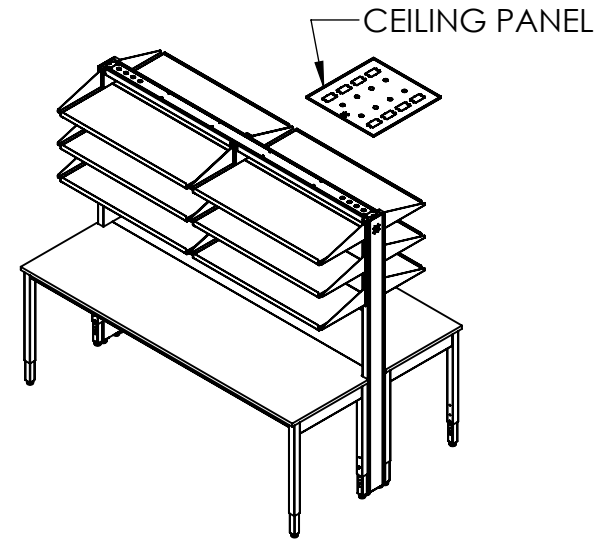
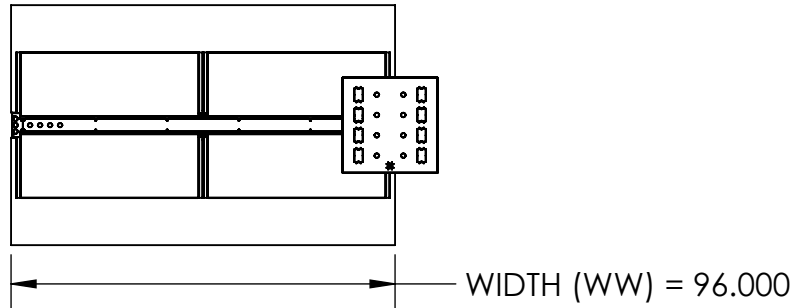

ONEPOINTE SOLUTIONS
 DRAWING DATE: 1/5/2021
 DRAWN BY: DVEERSHETTY
 TOLERANCE: ±.005 IN.
 DO NOT SCALE DRAWING
 ALL UNITS IN INCHES

PART # FLEX SYSTEM ASSEMBLY - CUTSHEET
 DESCRIPTION: FLEX SYSTEM - CUTSHEET

MATERIAL:
 GROUP:
 REV: 20.05.01

FLEX SYSTEM ASSEMBLY - CUTSHEET
FLEX SYSTEM ASSEMBLY - 96 - SINGLE SIDED

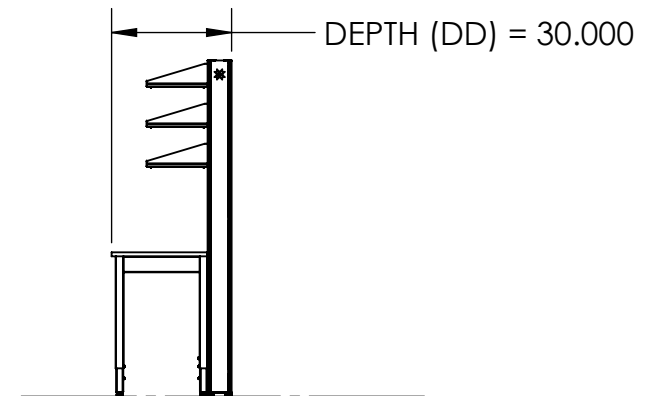
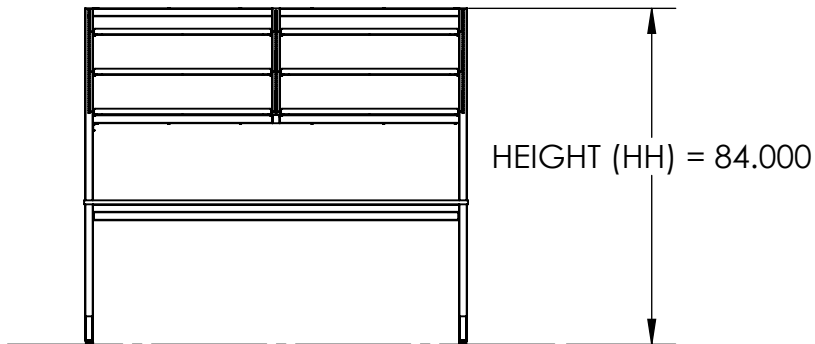
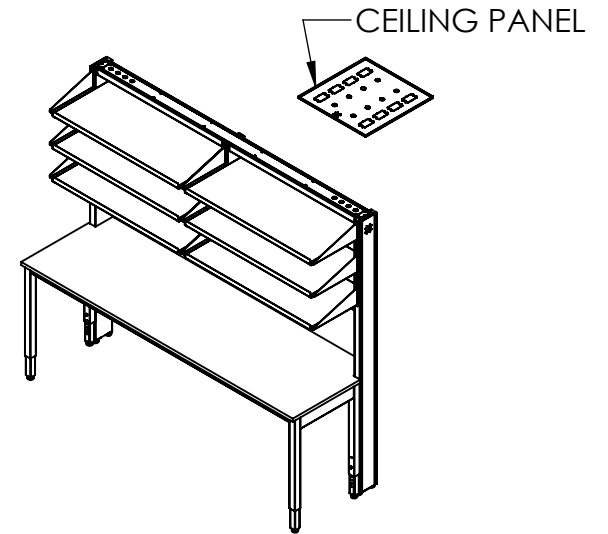
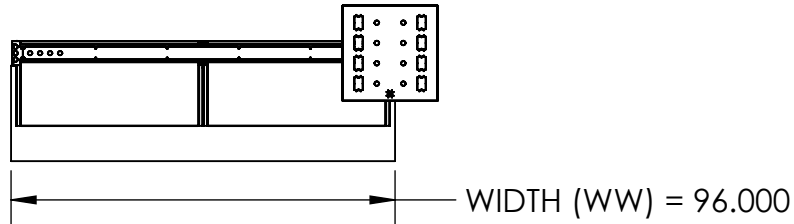

ONEPOINTE SOLUTIONS
DRAWING DATE: 1/5/2021
DRAWN BY: DVEERSHETTY
TOLERANCE: ±.005 IN.
DO NOT SCALE DRAWING
ALL UNITS IN INCHES

PART # FLEX SYSTEM ASSEMBLY - CUTSHEET
DESCRIPTION: FLEX SYSTEM - CUTSHEET

MATERIAL:
GROUP:
REV: 20.05.01

FLEX SYSTEM ASSEMBLY

UPRIGHT ASSEMBLY + TABLE FRAME (s) - CUTSHEET

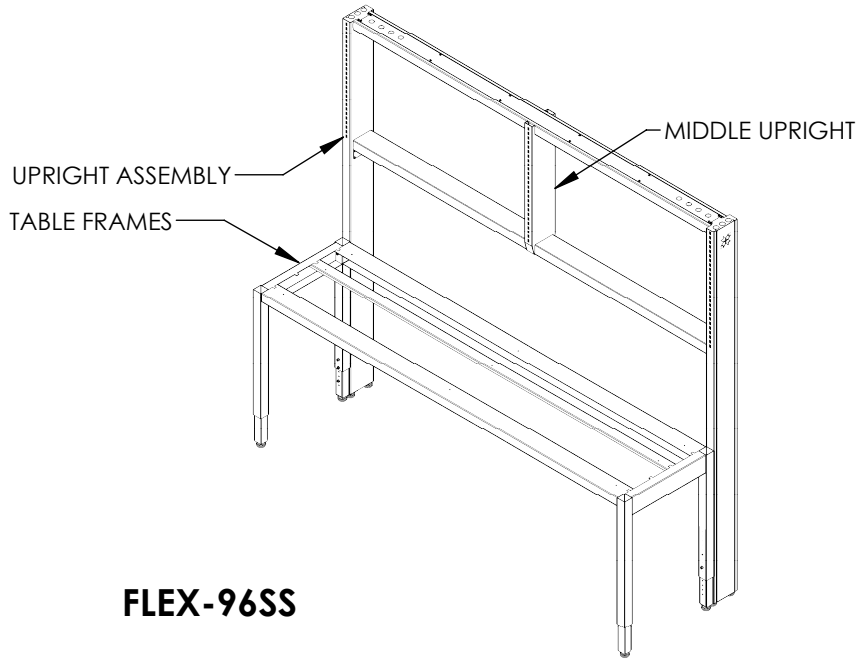

FLEX-96SS

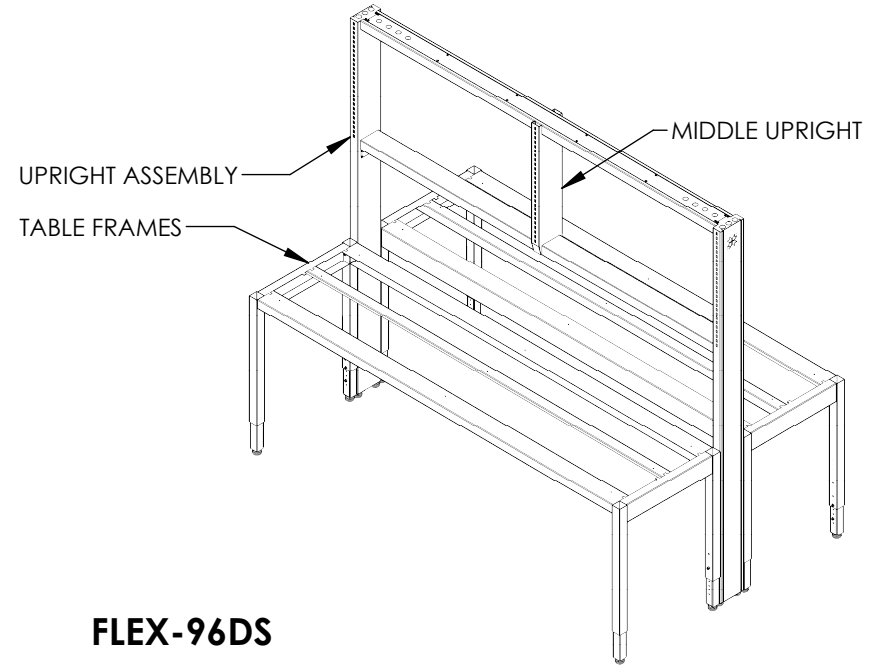

FLEX-96DS

FEATURES -

- THIS SKU KIT CONSISTS OF AN UPRIGHT ASSEMBLY AND TABLE FRAME(s).
- A DOUBLE-SIDED SKU WILL ADD TWO FRAMES.
- MIDDLE UPRIGHT GETS ADDED AT WIDTHS 54" AND ABOVE.
- COUNTER TOPS AREN'T INCLUDED, NEEDS TO BE PURCHASED SEPARATELY.

PRODUCT CONFIGURATION GUIDE -

PRODUCT LINE	-	WIDTH	DOUBLE/SINGLE-SIDED
FLEX	-	36, 42, 48, 54, 60, 66, 72, 84, 96	DS/SS

ONEPOINTE SOLUTIONS

DRAWING DATE: 1/5/2021

DRAWN BY: DVEERSHETTY

FLEX SYSTEM ASSEMBLY - CUTSHEET

Description: UPRIGHT ASSEMBLY + TABLE - CUTSHEET

REV: 20.05.01

SHEET 4 OF 7

FLEX SYSTEM ASSEMBLY COUNTERTOPS - CUTSHEET

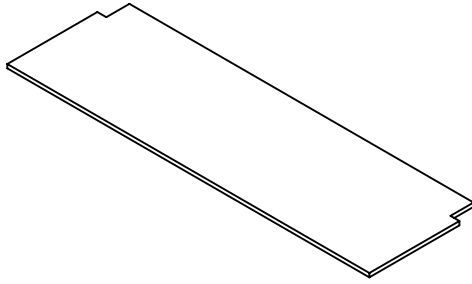

FX-PRL1.0-96X30-SS

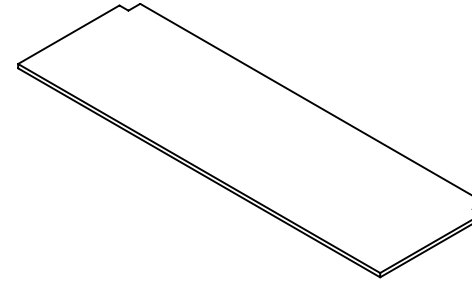

FX-PRL1.0-96X30-DS

FEATURES -

- THIS SKU CONSISTS OF ONE COUNTERTOP.
- TWO COUNTERTOPS NEED TO BE ADDED FOR A DOUBLE-SIDED (DS) SYSTEM.

PRODUCT CONFIGURATION GUIDE -

PRODUCT LINE			-	WIDTH	X	DEPTH	-	DOUBLE/SINGLE-SIDED
FX	-	PRL1.0, IPRL1.0, ER1.0	-	36, 42, 48, 54, 60, 66, 72, 84, 96	X	30	-	DS/SS

- IPRL = INTERNAL PHENOLIC RESIN LAB-GRADE
- PRL = PHENOLIC RESIN LAB-GRADE
- ER = EPOXY RESIN

ONEPOINTE SOLUTIONS

DRAWING DATE: 1/5/2021

DRAWN BY: DVEERSHETTY

FLEX SYSTEM ASSEMBLY - CUTSHEET

Description: DOUBLE-SIDED FLEX SYSTEM

REV: 20.05.01

SHEET 5 OF 7

FLEX SYSTEM ASSEMBLY SHELVES - CUTSHEET

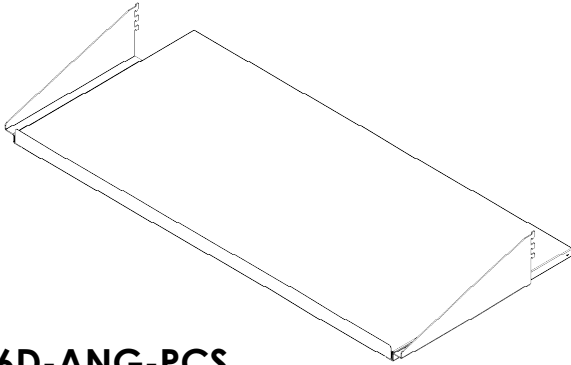

FXSAS-SS-4816D-ANG-PCS

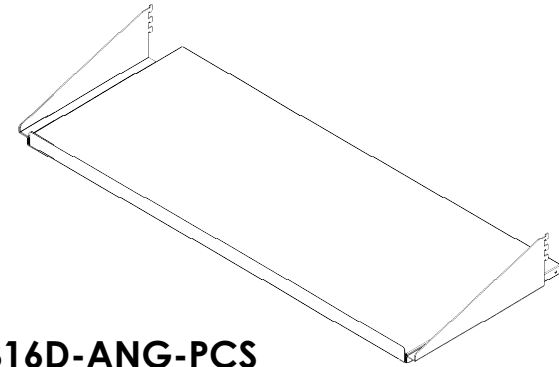

FXSAS-DS-4816D-ANG-PCS

FEATURES -

- THIS SKU CONSISTS OF ONE SHELF.
- TWO SHELVES NEED TO BE ADDED TO COMPLETE A ROW OF SHELF FOR WIDTHS 54" AND ABOVE.

WIDTH OF SINGLE SHELF FOR 16" DEPTH

- 36" - 3616
- 42" - 4216
- 54" - 2716D
- 60" - 3016D
- 66" - 3316D
- 72" - 4216D
- 84" - 4216D
- 96" - 4816D

PRODUCT CONFIGURATION GUIDE -

PRODUCT LINE	DOUBLE/SINGLE-SIDED	DIMENSION	BRACKET PROFILE	SHELF LIP
FXSAS	DS/SS	3613, 4213, 4813, 2713D, 3013D, 3313D, 3613D, 4213D, 4813D, 3616, 4216, 4816, 2716D, 3016D, 3316D, 3616D, 4216D, 4816D	ANG = ANGLED	PCS

ONEPOINTE SOLUTIONS

DRAWING DATE: 1/5/2021

DRAWN BY: DVEERSHETTY

FLEX SYSTEM ASSEMBLY - CUTSHEET

Description: SHELF - CUTHSEET

REV: 20.05.01

SHEET 6 OF 7

FLEX SYSTEM ASSEMBLY CEILING PANEL - CUTSHEET

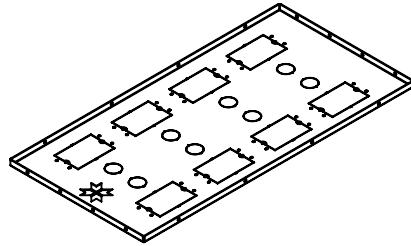

FXCP-1224

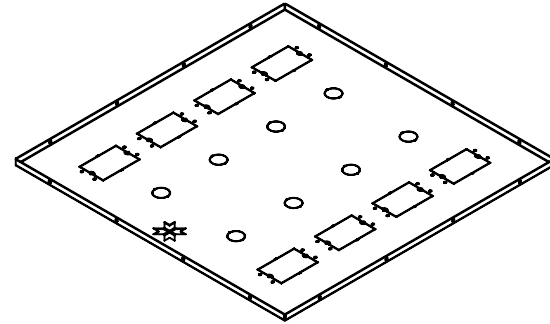

FXCP-2424

FEATURES -

- A CEILING PANEL CAN BE SHARED BY 2 ADJACENT FLEX SYSTEMS.
- THEY CAN HOLD A MAXIMUM OF 4 PLUMBING SERVICES AND 4 ELECTRICAL CONNECTIONS PER FLEX SYSTEM WHEN SHARED.

PRODUCT CONFIGURATION GUIDE -

PRODUCT LINE	-	WIDTH	DEPTH
FXCP	-	12, 24	24