

ONEPOINTE SOLUTIONS

PRESENTS

PRODUCT INSTRUCTIONS



HOW TO GUIDES TO SUCCESSFULLY AND EFFICIENTLY
INSTALL OUR PRODUCTS

WALL UPRIGHT ASSEMBLY



WALL UPRIGHT ASSEMBLY

INSTRUCTIONS: STEP 1

ITEM NO.	PART NUMBER	DESCRIPTION	QTY.	REVISION
1	.25-20 WALL TOGGLE	.25-20 STEEL WALL TOGGLE	6	-
2	HCAP-48	HANGAR CAP	1	A
3	SU-48	WALL SHELF UPRIGHT	2	A
4	UH-48	UPRIGHT HANGAR	1	A

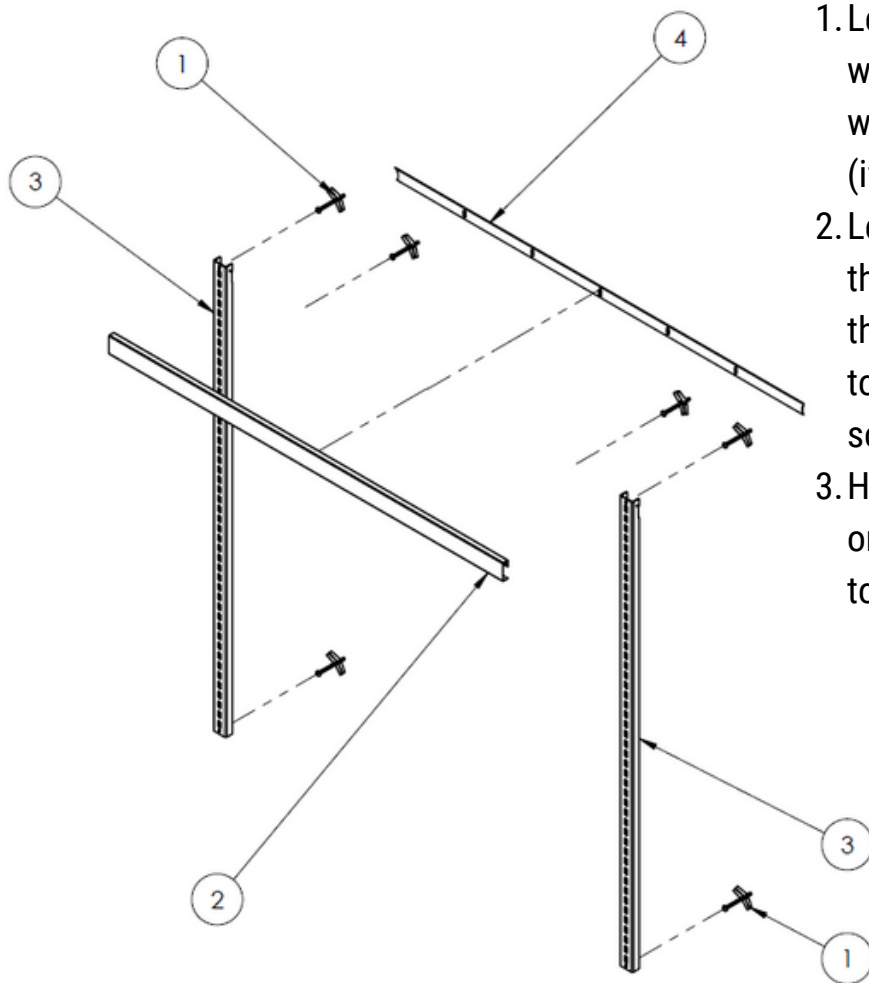

1. Level the upright hangar to horizontal on the wall, mark through the holes for drilling to install wall toggles (if it is a dry wall) / anchored studs (if it is a solid wall such as concrete or stone).
2. Level the uprights after hooking each other at their top to the hangar to be vertical, mark through the holes for drilling to install wall toggles (if it is a dry wall)/ anchored (if it is a solid wall such as concrete or stone).
3. Hook the hangar cap between the two uprights onto the hangar to conceal the hangar and the toggles.



WALL UPRIGHT ASSEMBLY

INSTRUCTIONS: STEP 2

ITEM NO.	PART NUMBER	DESCRIPTION	QTY.	REVISION
1	31831	#8 X 1/2" DRILLING SCREW	12	20.07.01
2	WSWB-4813	WALL SHELF WITH BRACKETS	3	A-15
3	WUA-4850	WALL UPRIGHT ASSEMBLY - ASSEMBLY INSTRUCTIONS	1	A-15

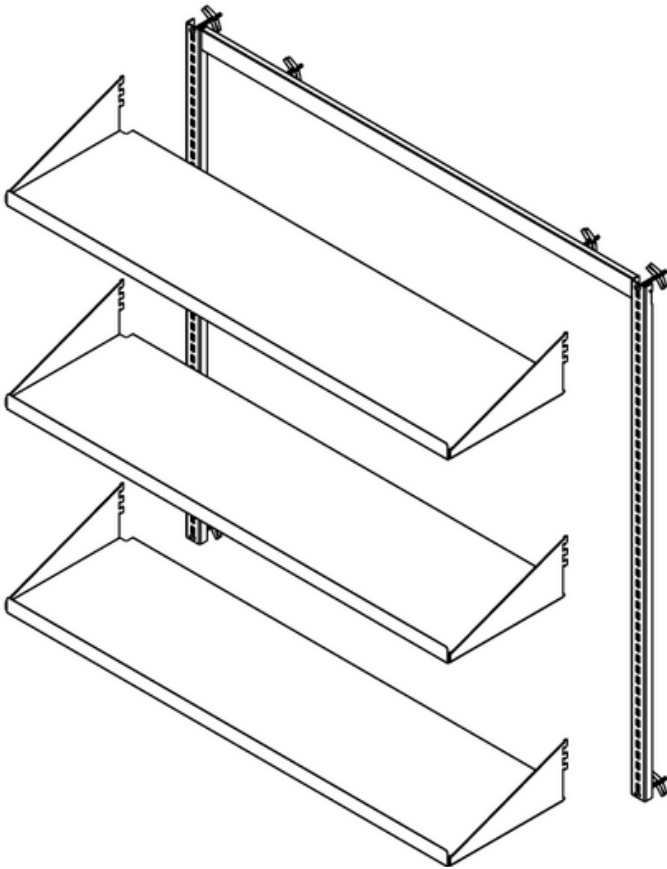

1. Install the shelf brackets onto each shelf using #8 self-tapping screw.
2. Hook each shelf onto the uprights, ensuring they match the hole level on either uprights with appropriate spacing between each shelf.

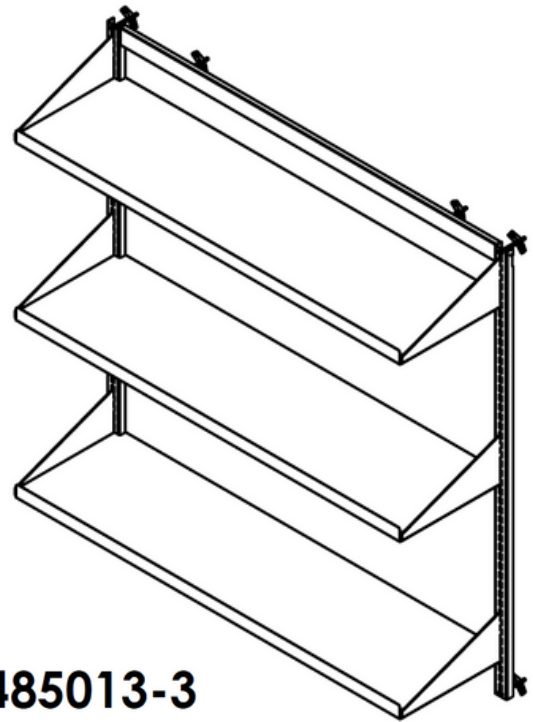

***FOR WSS-485013-3
AS SHOWN IN PICTURE**



CONTACT INFORMATION

For any questions or concerns contact us

(866) 612-7312

info@onepointesolutions.com

1112 Swenson Blvd.

Elgin, Texas 78621

