

ONEPOINTE SOLUTIONS

PRESENTS

PRODUCT INSTRUCTIONS



HOW TO GUIDES TO SUCCESSFULLY AND EFFICIENTLY
INSTALL OUR PRODUCTS

ISLAND SHELVING SYSTEM



ISLAND SHELVING ASSEMBLY

PARTS

ITEM NO.	PART NUMBER	DESCRIPTION	QTY.
1	ISUA-48	ISLAND SHELVING UPRIGHT ASSEMBLY	4
2	ISWB-5412	ISLAND SHELF WITH BRACKETS (BOTTOM)	3
3	ISWB-5415T	ISLAND SHELF WITH BRACKETS (TOP)	3
4	ITCHAN-I-54	ISLAND TOP CHANNEL (INNER)	1
5	ITCHAN-O-54	ISLAND TOP CHANNEL (OUTER)	2

**ISS-48164 SHOWN IN DIAGRAM
FOR INSTRUCTIONS**

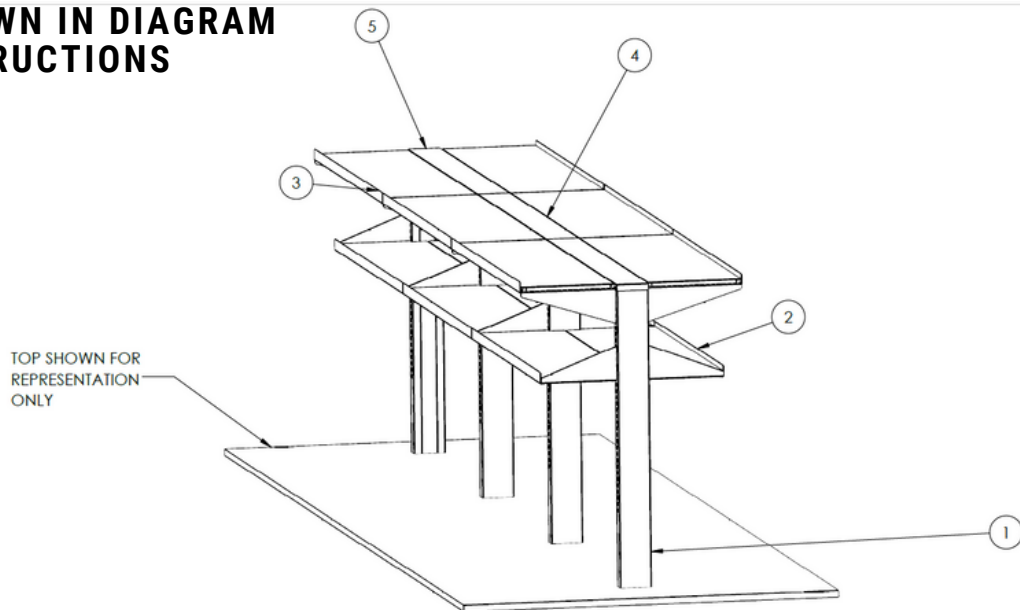

ISLAND SHELVING ASSEMBLY

STEP 1. MOUNTING THE UPRIGHTS

Mount the upright assembly (1) to the table top using the bolts on the bottom of the uprights, washers and hex nuts as shown in the detail view above.

STEP 2. FASTENING TOP CHANNELS

Fasten the top channels to the uprights and screw them on using self tapping screws in the holes provided. Note that inner top channels (4) fit different than the outer top channel (3).

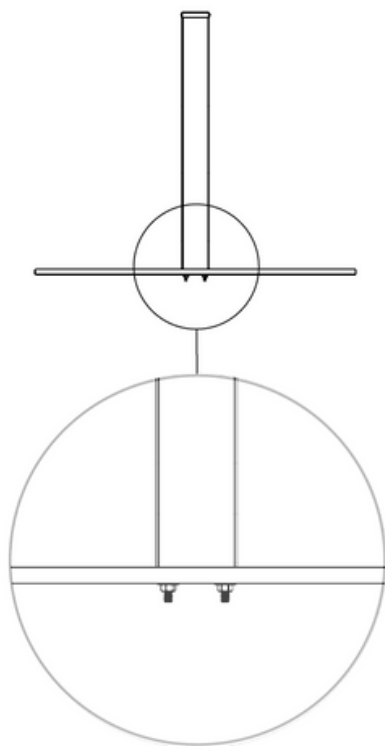

Detail View

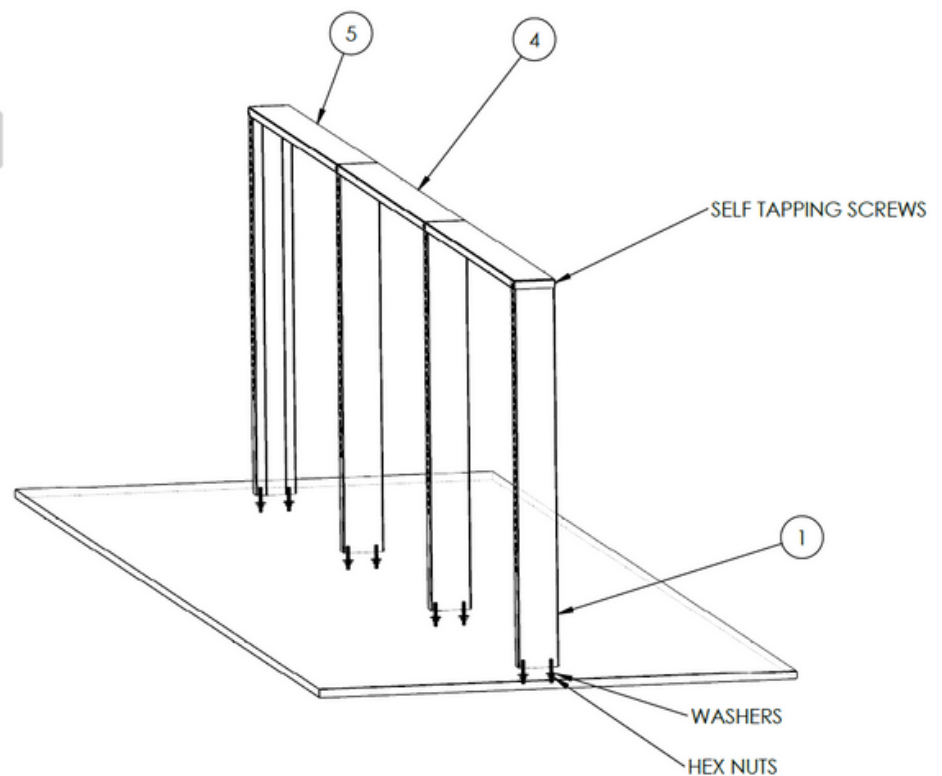

ISLAND SHELVING ASSEMBLY

STEP 3. PREPARING THE SHELF ASSEMBLIES

Attach the shelves to their respective brackets with 4 self-tapping screws. Note that the shelf brackets and the shelf for the top shelves are different from the lower shelves.

STEP 4. ATTACHING THE SHELF ASSEMBLY

Mount the top shelf to the top three slots on the uprights. The bottom shelf can be mounted at any height desired. It is recommended that shelves facing each other be mounted at the same height.

Look at the next page for how the island shelving system needs to look after assembly.

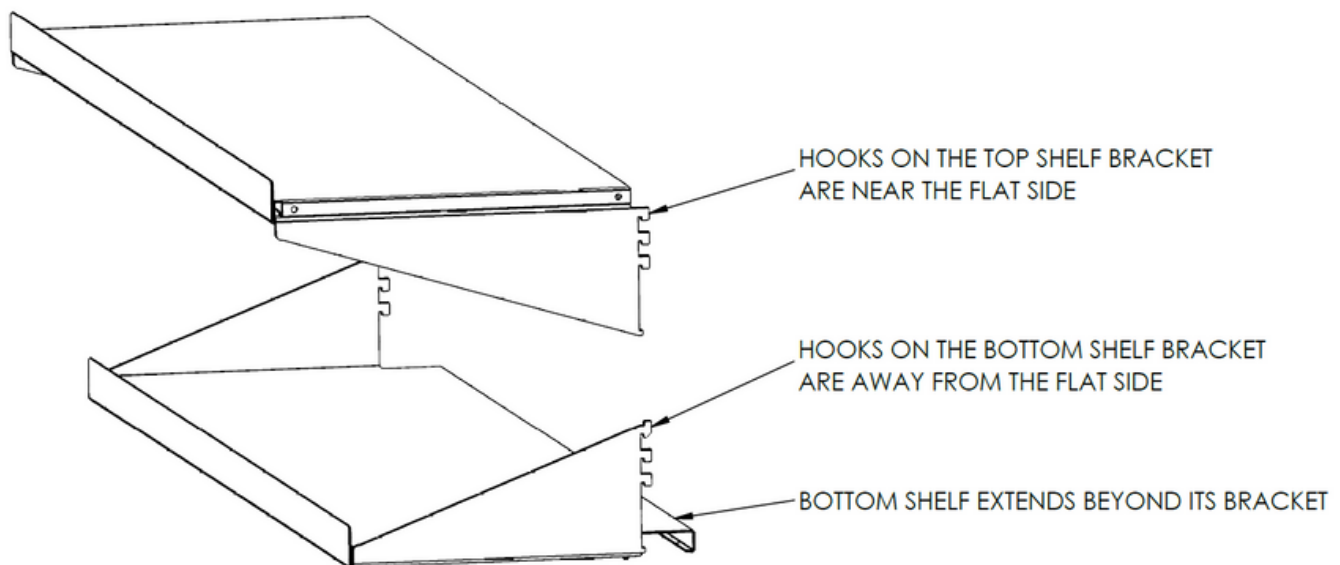

ISLAND SHELVING ASSEMBLY

FINISHED PRODUCT

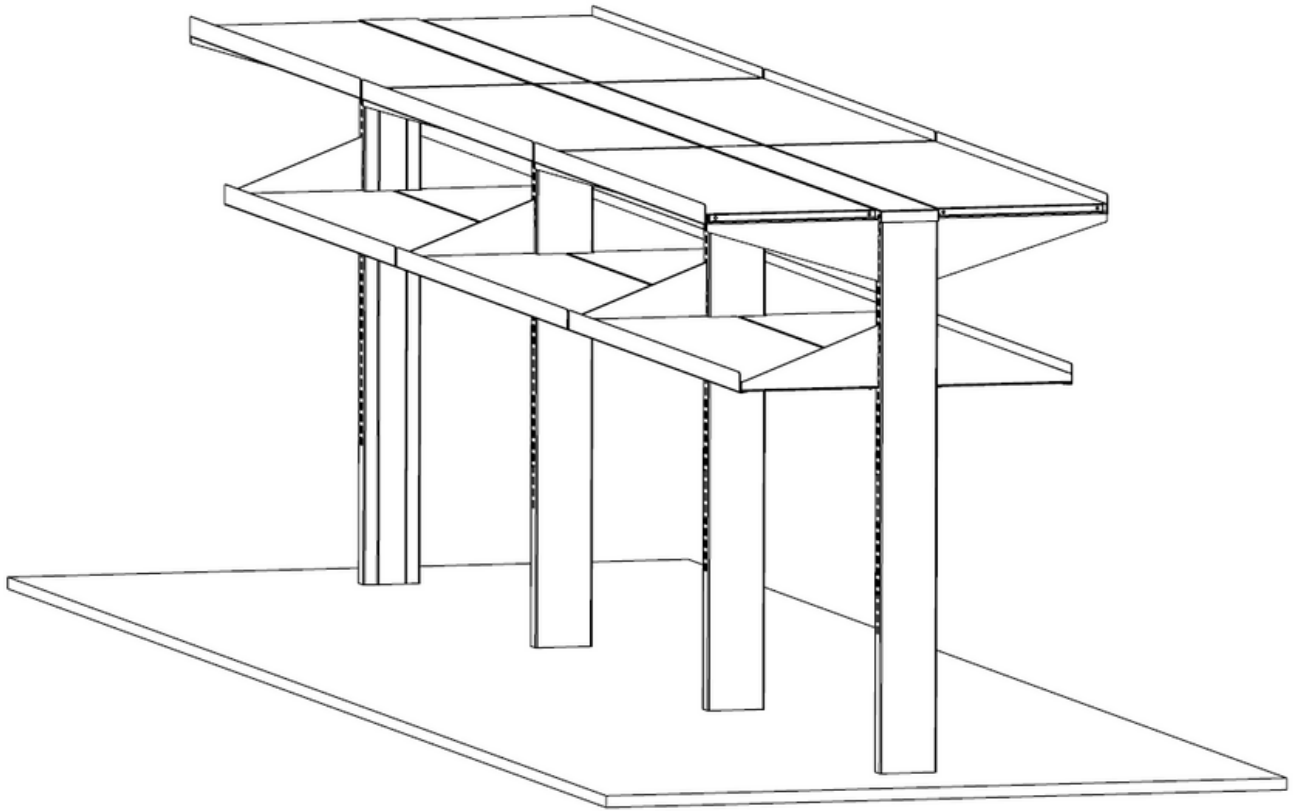

CONTACT INFORMATION

For any questions or concerns contact us

(866) 612-7312

info@onepointesolutions.com

1112 Swenson Blvd.

Elgin, Texas 78621

