

TANDEM plus BLUMOTION 569H/569. heavy duty

Application



New features

- Four-dimensional adjustment
- Elongated holes for depth adjustment
- 150 lb static load capacity

Description

- Full extension concealed drawer runners
- Panel or blocked-out face frame cabinets
- BLUMOTION soft closing
- TANDEM smooth running action
- Available in 18" to 30" lengths
- 13 (1/2") to 16 (5/8") drawer thickness

Basic components

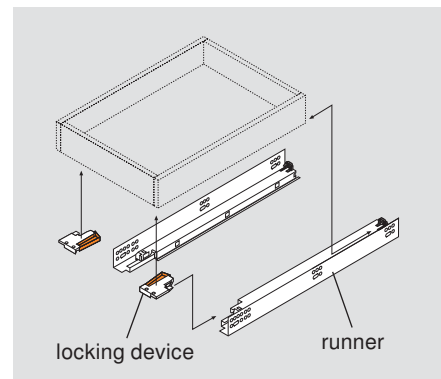

Other applications

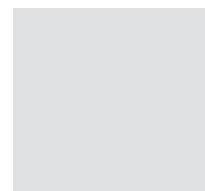
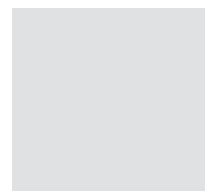
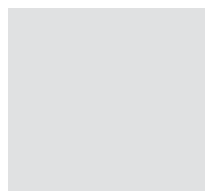
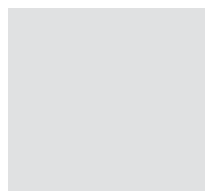

Components

Runner set

One set required per drawer



for overall cabinet depth	drawer length	TANDEM plus BLUMOTION
838 (33")	762 (30")	569.7620B
762 (30")	686 (27")	569.6860B
686 (27")	610 (24")	569.6100B
610 (24")	533 (21")	569H5330B
533 (21")	457 (18")	569H4570B
Wood screw for installation		606N or 606P
System screw for installation		662.1150.HG

Side adjustable locking device



- One right and one left required per drawer
- With side-to-side adjustment
- Captive right and self-aligning left device
- Self-adjusting drawer length tolerance
- Steel base with synthetic, spring-loaded release levers
- Minimum inside drawer width 170 (6-11/16")
- Height adjustment +3 (1/8")
- Side adjustment ±1.5 (1/16")
- For use with 563/569 series runners only
- For other options see page 32

Part no.

Right locking device **T51.1901 R**

Installation Left locking device **T51.1901 L**

page 11 Installation screw **606N or 606P**

NOTE: For heavy duty applications, rear brackets and sockets cannot be used. Cabinet sides must be blocked-out flush with the inside of the frame. See page 19.

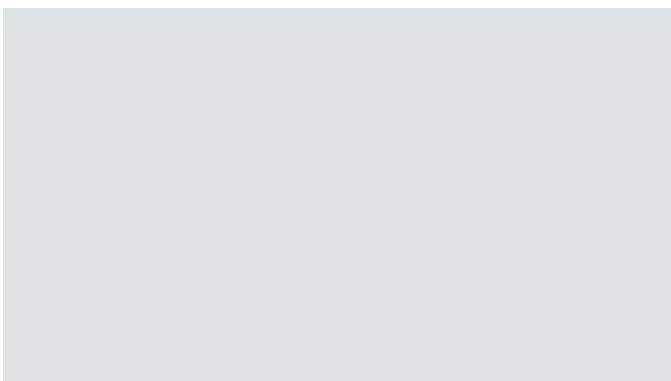

Using TANDEM **page 10**

Drawer preparation **page 11**

Accessories **page 42**

Assembly aids **page 44**

Maximum drawer thickness 16 (5/8")

Lengths available 18" - 30"

Static load capacity 150 lb

Drawer and cabinet specifications

Drawer box specifications

Front view

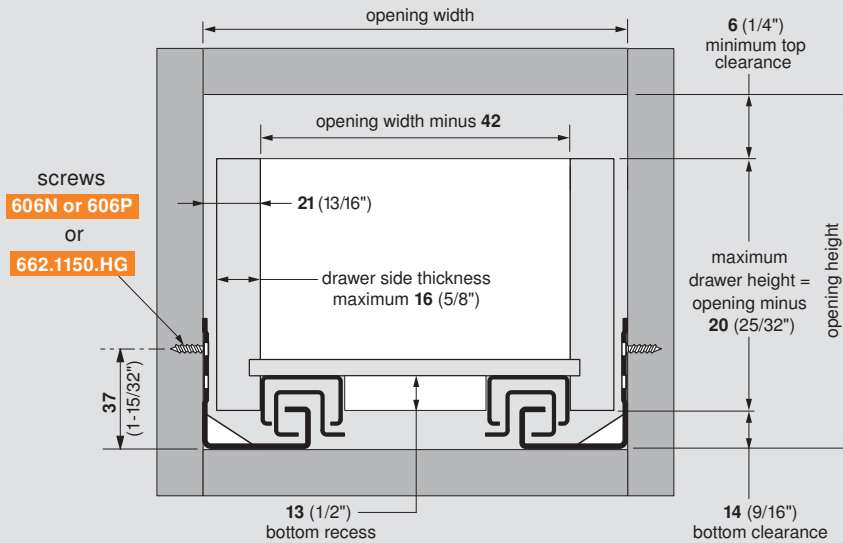

NOTE: Material thickness may vary. Inside drawer width **must** equal opening width minus 42 for TANDEM to align and function properly.

Drawer back preparation

Rear view

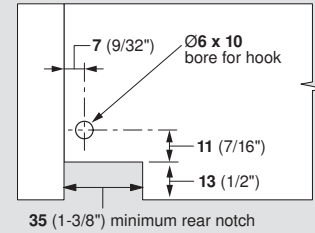

Runner comparison

Side view

569H



569.

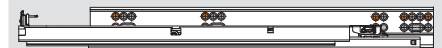

Runner mounting specifications

Side view

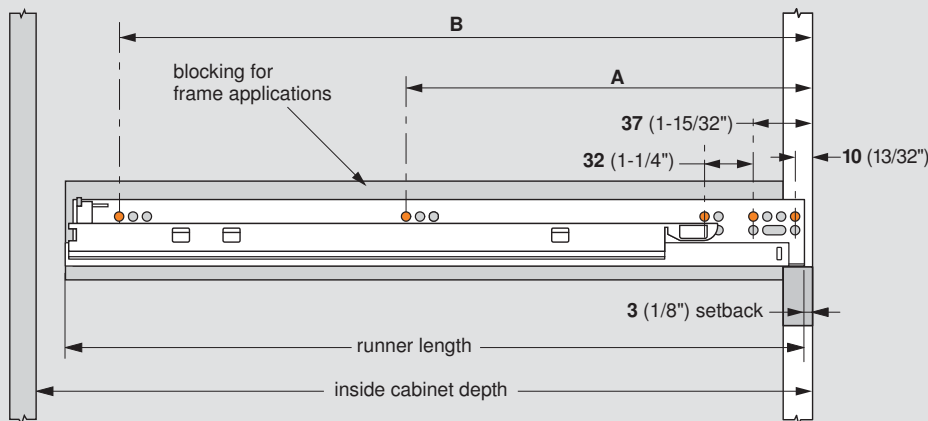

Runner close-up

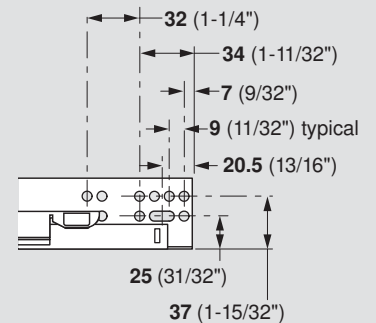

NOTE: Elongated holes are for ±4.5 (3/16") depth adjustment only. Additional screws must be used to secure the runner to the cabinet.

NOTE: The orange dots indicate fixing screw locations required to meet specified load ratings

TANDEM plus BLUMOTION	drawer length	minimum inside cabinet depth	runner length	screw locations	
				A	B
569.7620B	762 (30")	786 (30-15/16")	777 (30-19/32")	261 (10-9/32")	389 (15-5/16")
569.6860B	686 (27")	709 (27-29/32")	700 (27-9/16")	261 (10-9/32")	389 (15-5/16")
569.6100B	610 (24")	634 (24-31/32")	625 (24-19/32")	261 (10-9/32")	389 (15-5/16")
569H5330B	533 (21")	557 (21-15/16")	548 (21-9/16")	261 (10-9/32")	517 (20-11/32")
569H4570B	457 (18")	480 (18-29/32")	471 (18-17/32")	261 (10-9/32")	453 (17-27/32")