

disc tumbler cylinder cam locks

MOUNTING HOLES FOR ALL CAM LOCKS

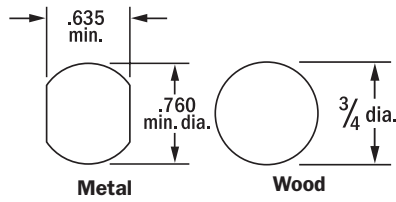

CAM DIMENSIONS

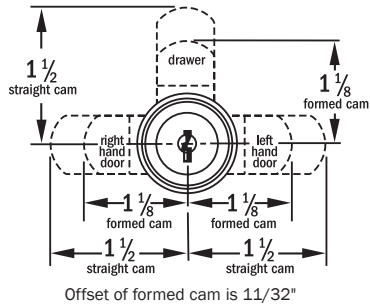

LOCK APPLICATION

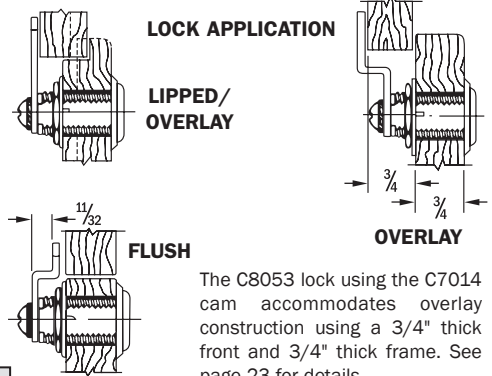

The C8053 lock using the C7014 cam accommodates overlay construction using a 3/4" thick front and 3/4" thick frame. See page 23 for details.

All locks feature FlexaCam™

U.S. Patent No. 9,512,653. Three spacers enclosed with most CompX National threaded disc tumbler cam locks offer three thicknesses – providing up to 12 different dimensional variations.

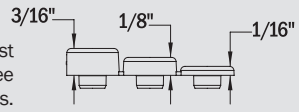

APPLICATION – For drawers, R.H. or L.H. doors with lipped/overlay construction (straight cam) or flush construction (formed cam). For overlay application, the combined thickness of front and frame cannot exceed the cylinder length. Also see overlay detail at above right.

OPERATION – 90° cam turn on all locks. Key removable in both locked and unlocked positions.

KEYING – Will key together with all other disc tumbler locks using D8785 key blank. See table for available keying. Master keying to E41A using D8783 key blank.

PACKAGING – Supplied with two keys, trim washer, spur washer (for wood), mounting nut and two cams. If flat washer (for metal) is needed, order C2015-2C separately. See page 22.



C8051



**C8052,
C8053,
C8054,
C8055**

Locks furnished with cams unassembled

Part No.	Type of Mounting	Cylinder Length	Maximum Material Thickness	KA * Codes	Key Changes		Case Quantity	Reference Number	Non MK Key Blank
					KD	MKKD			
C8051-14A	Lipped/Overlay or Flush	7/16"	7/64"	10	200	200	25	M4-0553	D8785
C8051-3		7/16"	7/64"	3	200	—	25	M4-0553	D8785
C8052-14A		5/8"	15/64"	10	200	200	25	M4-0054	D8785
C8052-3		5/8"	15/64"	3	200	—	25	M4-0054	D8785
C8054-14A		15/16"	5/8"	10	200	200	25	M4-0054B	D8785
C8054-3		15/16"	5/8"	3	200	—	25	M4-0054B	D8785
C8054-4G		15/16"	5/8"	3	200	—	25	M4-0054B	D8785
C8053-14A		1-3/16"	7/8"	10	200	200	25	M4-0054C	D8785
C8053-3		1-3/16"	7/8"	6	200	200	25	M4-0054C	D8785
C8053-4G		1-3/16"	7/8"	6	200	200	25	M4-0054C	D8785
C8055-14A		1-7/16"	1-1/8"	10	200	200	25	M4-0054L	D8785
C8055-3		1-7/16"	1-1/8"	6	200	200	25	M4-0054L	D8785
C8055-4G		1-7/16"	1-1/8"	6	200	200	25	M4-0054L	D8785

*Key Codes used: 3 Codes – C346A, C413A and C415A.

6 Codes – C346A, C390A, C413A, C415A, C420A and C642A.

10 Codes – C205A, C267A, C346A, C361A, C390A, C413A, C415A, C420A, C441A and C642A.